



ABOUT US

By 2015 DIPAUL group have accumulated over 20 years of significant experience in electronics and semiconductor industries market, offering solutions, technologies and equipment. In the course of these years some major companies from military-industrial and aerospace sectors, contract manufacturers, research and educational organizations, service and repair providers, telecommunication operators and other enterprises have become our clients.

Over 10 years ago, understanding all our clients' needs and requirements, we started manufacturing workplaces for electronics devices assembly under VIKING brand. We were the first in Russia to develop new technologies and use new materials to manufacture antistatic furniture, which complies with international IEC 61340. By now we became a leading Russian producer of ESD workbenches, storage units and additional equipment for electronic industry. VIKING ESD workbenches and other products have practically become a top standard for Russian radio electronics companies. Dipaul group has implemented dozens of equipping projects for such Russian companies as Transneft, Gazprom, Rosenergoatom, Russian Space Systems and international companies like Samsung Electronics, LG Electronics, Volkswagen Group, Nissan Manufacturing, Elcoteq, TPV Technology, and Foxconn. In the past 12 years we have furnished thousands of Russian industrial enterprises, since 2007 we also sell our products to European electronics and semiconductor industry companies from Belgium, Czech Republic, Finland, France, Germany, Hungary, Netherlands and others.

VIKING ESD and technical furniture manufacturing site is located near Saint-Petersburg and occupies the territory of over 6.000 square meters. In metal cutting area, painting zone and woodshops antistatic and technical furniture is produced, then processed in assembling and packing sections and stored in a spacious warehouse.

We constantly monitor manufacturing process and quality of our workbenches on all stages, which is acknowledged by ISO 9001:2008 certificate. For antistatic furniture, strict compliance with IEC 61340 is guaranteed.

VIKING TECHNICAL AND ESD FURNITURE

Today VIKING brand offers a wide range of different workplaces, technical and ESD furniture and antistatic equipment. We designed and produce VIKING furniture as reliable, durable, ergonomic and easy to assemble products.

VIKING technical furniture provides ergonomic working area for any company and is distinguished by:

- Wide range of functional, convertible and interchangeable modules for each particular employee;
- Adjustment, layout and customization according to clients' specific needs;
- Possibility of modernization and refitting after the purchase;
- Strict compliance with the international antistatic standard IEC 61340.

VIKING technical furniture product range includes workbenches of different types, drawer units, equipment trolleys, carts and shelving, storage and wardrobe cabinets, ESD chairs and other ESD equipment and accessories. Most furniture units are offered in two versions - antistatic (ESD-protected) and technical ones.

VKG TOOLS ESD EQUIPMENT

Besides a broad line of furniture, we offer a range of antistatic products and consumables to fully equip ESD-protected areas. Among them, one can find garments, storage and transportation means, monitoring and audit devices. These products are sold under VKG TOOLS brand.

In 2013 DIPAUL group has opened its branch office and a central distribution warehouse in Prague (Czech Republic) to provide a close support to its partners and distributors in the European region. Dipaul s.r.o. works on developing business relations with EU and ME distributors, supply Viking products from Czech warehouse to customers, ensure informational and technical support.

TABLE OF CONTENT

VIKING technical furniture Configurator	4
Online 3D workspace Planner	5
Our customers	6
- VIKING workplaces series	9
- ALPHA series workbenches	10
- ALLIANCE series workbenches	12
- ALLIANCE automatic workbenches	14
- CLASSIC series workbenches	16
- COMFORT series workbenches	18
- CONSTANT series workbenches	20
- OSTROV series workbenches	22
- VERSTAK series heavy duty workbenches	24
- Universal workbenches	26
Specialized workbenches	26
Wire harness workbench	28
Wire harness workbench accessories	29
Alpha universal workbench	30
Customized layouts	31
Workplaces additional equipment, grounding equipment	32
Fully automated turnstile system	37
Drawer units	38
- Enlarged cabinets and drawer units	40
- Additional equipment for drawers	40
- ALPHA cabinet	41
Movable tables and carts	42
Movable trolleys	44
Cabinets and wardrobes	46
Sliding shutters cabinets	48
Shelving	49
Modular counters	50
ESD chairs	52
ESD garments	54
Clean room Garments and Accessories	56
ESD storage and packaging	58

VIKING

VKG TOOLS

VIKING TECHNICAL FURNITURE CONFIGURATOR



Most VIKING technical and ESD workbenches consist of functional and interchangeable modules to provide maximum flexibility and help the customers to create customized workplaces, which satisfy any specific working process requirements. It may become an uneasy process to assemble certain set and make a choice of elements guided solely by modules description and codes. With our online service – VIKING technical and ESD furniture Configurator (www.viking-esd.com/configurator), which interactively guides user along the process of workbench assembling, it's much easier to make the right choice.

VIKING technical and ESD furniture Configurator helps to choose necessary basic modules and additional equipment of a future workplace online. It simplifies the process of assembling a workbench set, saves time and helps to avoid possible mistakes in different modules compatibility.

After choosing required options and elements one can place an order for chosen set to any VIKING official distributor online, print the individual set or use the picture and the list of modules for future orders.

VIKING technical furniture Configurator is also useful for workplaces amendment. Any time after the purchase customer can add or change workplaces' modules so that differently equipped workplaces are able to meet new requirements of the manufacturing process or any changed conditions.

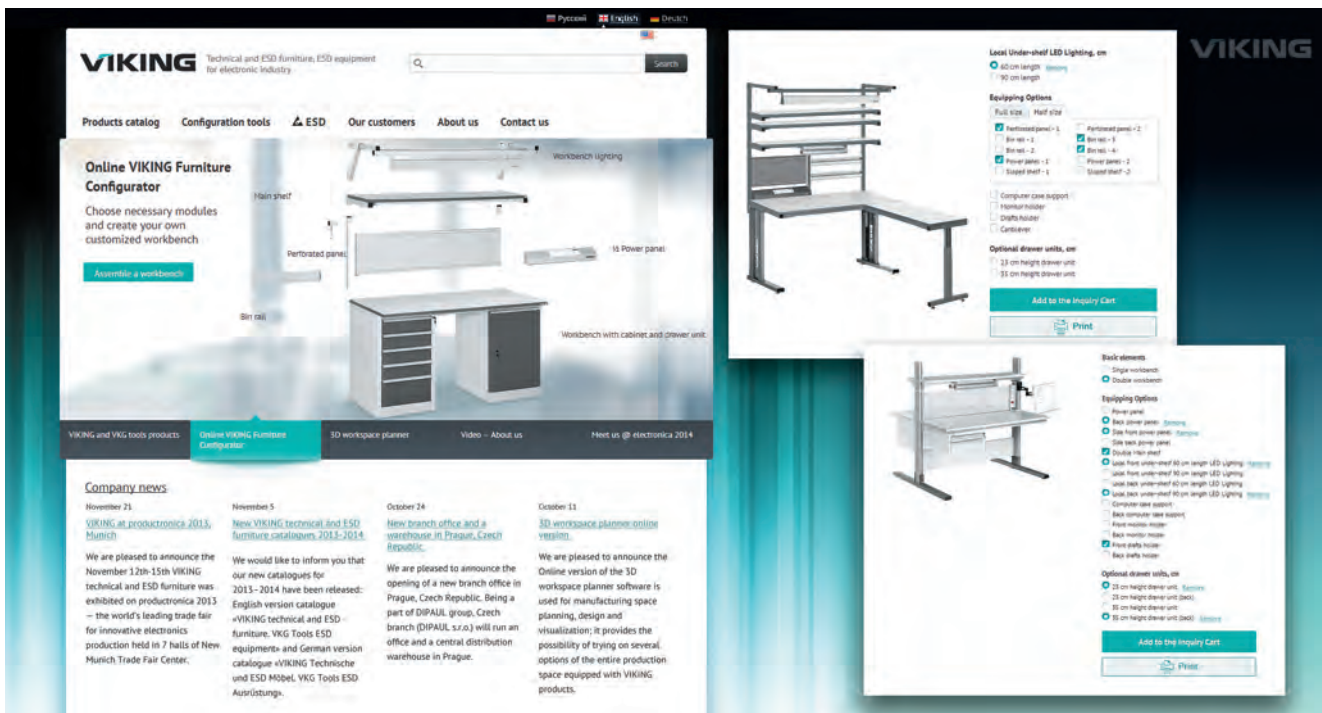

ONLINE 3D WORKSPACE PLANNER

The 3D online workspace planner software is used for manufacturing space retrofitting planning, design and visualization; it provides the possibility of trying on several options of the entire production area equipment with VIKING furniture and additional elements.

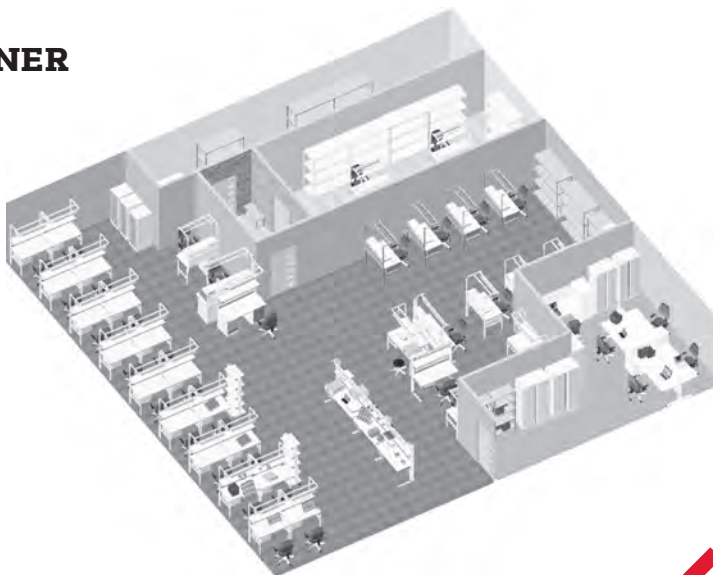

While being on the stage of planning new manufacturing facilities, workspace refurbishing or re-equipping it's very useful to have the ability to compare different types of furniture and equipment layouts. Using the exact halls dimensions 3D Planner user can build up a 3D plan of the hall, estimate the quantity of necessary technical furniture and their disposition, arrange workplaces, passageways and utility premises. Our online 3D workspace Planner allows to specify windows, doors, columns sizes and positions, and also to choose colors and shapes of additional elements.

Online software is free and can be used by any www.viking-esd.com visitor; one just needs to install a plug-in to their computer.

As a result of working in 3D workspace planner, a user gets visual plans of re-equipped halls in isometric, top and 3d front view and detailed list of chosen furniture and equipment. All hall plans can be saved in standard .jpg format images which are easy to be sent, viewed or printed. One can also save 3D designs in specific .o3d format and continue the work later.

OUR CUSTOMERS







ALPHA



ALLIANCE, ALLIANCE automatic



CLASSIC



COMFORT



CONSTANT



OSTROV



VERSTAK



UNIVERSAL



SPECIALIZED



VIKING WORKPLACES SERIES

Most of VIKING products are available in technical and ESD (antistatic) versions, the latter are marked with ESD [label](#).

Steel frames are powder-coated in dark grey (RAL 7012) or light grey (RAL 7035) color, tabletops are resistant to abrasion. VIKING workbenches are modular, allowing customers to order only necessary parts and get workplaces for any specific [use](#).

Sets of furniture can be supplemented by additional equipment at any time after the purchase. Assembly and installation is quick and simple, clear assembly instructions are provided with each module, they are also available for download from <http://viking-esd.com>. Worktops and shelves are designed to endure big loads. Rigid and robust construction of VIKING workbenches provides reliable usage and thought-out ergonomics – for comfortable work. VIKING ESD-protected products are compliant with IEC 61340 standard, have corresponding certificates and test [reports](#).

VIKING workbenches product range includes a wide line of functional, convertible and interchangeable modules for each particular enterprise. To facilitate configuration and simplify different elements choosing, our customers are welcome to use CONFIGURATOR (<http://www.viking-esd.com/configurator>), our online service which helps to interactively select all necessary workbench parts. After choosing required options and elements one can print the individual set and use the picture and the list of modules for future [orders](#).

We divide our workbenches and supplementary elements in several series; each has its own peculiarities:

- **ALLIANCE** workbenches are distinguished by elegant design, advanced ergonomics and convenient system of height adjustment. They can be placed in an inseparable line where each two tabletops are held by lateral frames and share those in the middle. Also available in double-sided version.
- **ALLIANCE Automatic** with motorized worktop adjustment system, performed by electric drive and simple control unit.
- **ALPHA** series workbenches are designed as an extension of Alliance series product line. Alpha series workbenches allow effective use of space, offer practical structures and a compact size.
- **ALPHA Universal** that are simplified Alpha workbenches without possibility of upper extensions.
- **CLASSIC** workplaces are simple, functional and inexpensive. They can be placed in a line with no gaps for conveyor work.
- **COMFORT** workbenches that look more appealing and offer advanced ergonomics for comfortable work.
- **CONSTANT** workbenches with fixed worktop height are equipped with functional supports and can withstand an increased load.
- **OSTROV** double-sided workbenches are designed for the most effective use of workspace.
- **VERSTAK** heavy duty workbenches are available only in non-antistatic version, but their rigidity and different tabletop and support types will be useful for manufacturing process.
- **UNIVERSAL** workbenches, the simplest and cheapest ones, they do not allow any above tabletop extensions.
- **SPECIALIZED** workbenches were made to satisfy specific working process requirements.

In addition, we can always manufacture customized products and are confident of our ability to satisfy and meet our customer's individual requirements.



ALPHA SERIES WORKBENCHES



EASY TO MAKE
A RIGHT CHOICE
VIKING
<http://viking-esd.com/configurator>

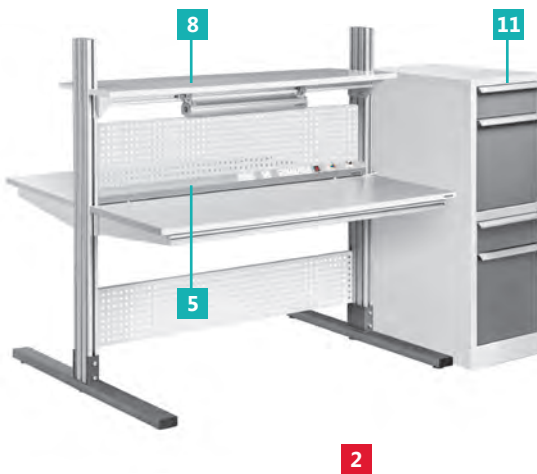
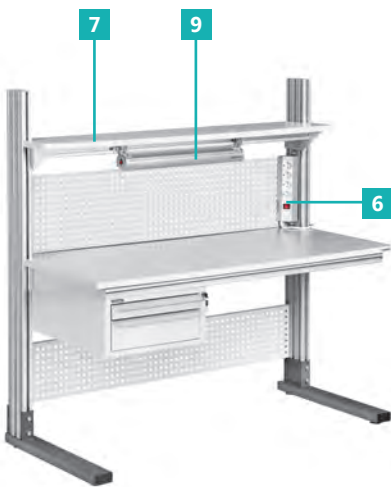

All ALPHA series modules are bicolored by default except for TP-01/P and TP-02/P optional drawer units and DL/N lighting unit that can be ordered in dark grey (RAL 7012) and light grey (RAL 7035) color. When ordering, please mention whether ESD or technical version required.

Alpha series workbenches are designed as a space-saving extension of Alliance series product line. Stylish and ergonomic workbenches can perfectly equip unspecified technical premises and educational facilities. Alpha series workbenches are distinguished by practical modular construction and compact size; they allow effective use of hall space.

We offer 3 models of Alpha series workbenches:

1 single workbench 2 double-sided workbench, 3 simplified universal workbench.

1 ALF Single workbench

This comfortable workbench is perfect for small premises which require space-saving equipment. It is recommended for office and engineering personnel, also used for training and educational premises.

Workbench is supplied in a set with 2 perforated panels.

- Adjustable tabletop height
- Workplace height: 1500 mm
- Load capacity: 200 kg

2 ALF-O Double workbench

Double-sided workbench with 2 tabletops, helps to save space and reduce costs. Workbench is supplied in a set with 2 double perforated panels and 2 tabletops.

- Adjustable tabletop height
- Workplace height: 1500 mm
- Each tabletop load capacity: 200 kg

3 ALF-U Alpha universal workbench

Simplified Alpha series workbench without upper modules.

Alpha universal workbenches allow several extensions:

- Optional drawer unit
 - Box with protective plastic fibers on box lid's edges and power panel
- See more on page 30.

4 ALF-EPA Power panel

Basic configuration consists of 4 sockets in an aluminium case with protective contact and 3 m cable. Can be equipped with additional sockets, fuses, phone jacks and earth leakage circuit breakers.

- Nominal load capacity: 10 A

5 ALF-O-EPA Double power panel

Basic configuration consists of 2 aluminium cases, each with 4 sockets with protective contact and 3 m cable. Can be equipped with additional sockets, fuses, phone jacks and earth leakage circuit breakers.

- Nominal load capacity: 10 A

6 ALF-EPA/B Side power panel

4 sockets with protective contact and 3 m cable in a small aluminium case. Side power panel can be mounted on any part of lateral aluminium frame. No extension possible.

- Nominal load capacity: 10 A

7 ALF-PO Main shelf

Main shelf for Alpha series single workbenches.

- 30 cm depth
- Load capacity: 70 kg
- Height adjustment: 1200 – 1500 mm.

CODE ↓	DIMENSIONS
ALF-12-7	1200x700 mm
ALF-15-7	1500x700 mm
ALF-18-7	1800x700 mm
ALF-O-12-7	2*(1200x700) mm
ALF-O-15-7	2*(1500x700) mm
ALF-O-18-7	2*(1800x700) mm
ALF-U-12	1200x700 mm
ALF-U-15	1500x700 mm
ALF-U-18	1800x700 mm

8 ALF-O-PO Double main shelf

Main shelf for Alpha series double workbenches.

- 30 cm depth from each side
- Load capacity: 150 kg
- Height adjustment: 1200 – 1500 mm.

9 DL/N Under-shelf local LED lighting

Additional lighting can be mounted under the main shelf or attached to perforated panel. Suitable for any workbench equipped with upper modules. It provides uniform illumination of the working area central zone.

- 2 versions: 60 cm length and 90 cm length
 - Light Source: LED lamps (30 pcs. for DL/N-6 and 45 pcs. for DL/N-9)
 - Angle adjustment $\pm 60^\circ$
 - Color temperature 4700 - 5300 K
 - Material of diffuser – 2 mm thick opal acryl
- Provides at least 1000 lux illuminance at 1000 mm distance from the light source.

10 TP-01/P, TP-02/P Optional drawer units

Storage solution for tools and components, no space on floor required. Each drawer is equipped with drawer's closer mechanism to provide sliding evenness.

- TP-01/P: 490x580x354 mm
- TP-02/P: 490x580x233 mm

11 ALF-TMB-02 cabinet

Spacious metal cabinet for documents, folders and personal belongings; can be attached to a workbench by bolts.

Cabinet is equipped with:

- 2 standard drawers
- 2 sliding shelves with perforated side wall, which can be placed on right or left side depending on further usage.

Dimensions: 445x1285x700 mm.

Distributed load capacity for each shelf: 30 kg.

Available only in technical version.

Additional equipment for ALF-TMB-02 cabinet

D-7/ALF-02 Horizontal dividers

7 horizontal 335 mm length dividers help to organize cells for different small items.

D-4/ALF-02 Vertical dividers

4 vertical 240x290 mm dividers help to organize slots for folders and documents.

See more on p.41.

ALLIANCE SERIES WORKBENCHES



EASY TO MAKE
A RIGHT CHOICE
VIKING
<http://viking-esd.com/configurator>

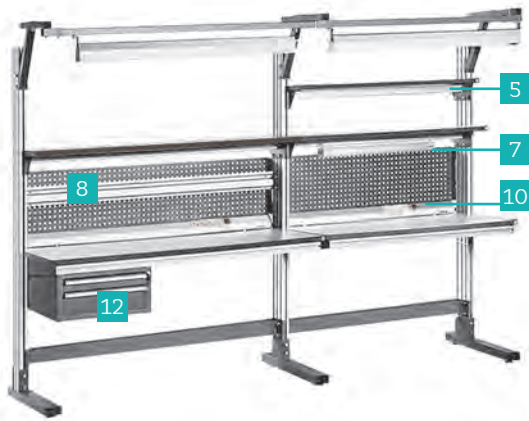

1

2

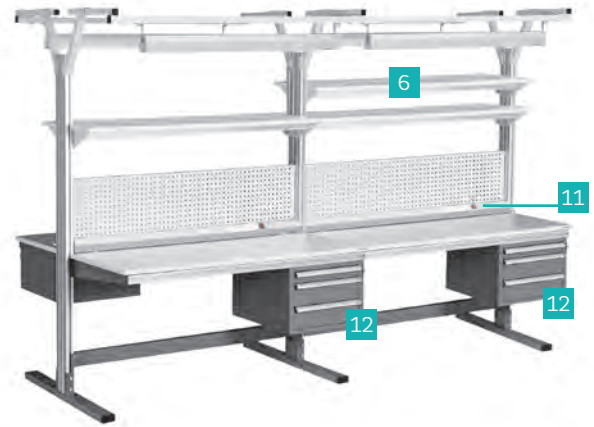

3

4

All ALLIANCE series modules are bicolored by default except for TP-01/P and TP-02/P optional drawer units and DL/N lighting unit that can be ordered in dark grey (RAL 7012) and light grey (RAL 7035) color. When ordering, please mention whether ESD or technical version required.

Alliance workbenches are distinguished by elegant design, advanced ergonomics and convenient system of height adjustment. Due to possibility of broadened worktop, main shelf and lighting height adjustments, these workbenches are very comfortable to work at, even in the upright position. One can quickly make any adjustments by his own and fix working surfaces by key wrenches.

We also offer motorized worktop adjustment embodied in Alliance Automatic series workbenches AL-A. See more on p.15.

Several Alliance workbenches can be placed in an inseparable line where two tabletops are held by side lateral frames and share those in the middle. Mirror-like double Alliance workbenches can also be put same way and build up total working area.

Possible tabletop height adjustment: 600 - 1300 mm.

Possible lighting height adjustment: 1200 - 2000 mm.

1 AL Alliance set

Single workbench with two lateral aluminium frames. The workbench is supplied in a set with lower slat, perforated panel, main shelf and lighting.

- Load capacity: 200 kg

2 AL/D Alliance additional set

Additional set with one lateral aluminium frame is meant to be attached to main Alliance workbench from either side, which provides inseparable working surface line.

The set includes: workbench with one lateral frame, lower slat, perforated panel, main shelf and lighting.

- Load capacity: 200 kg

3 AL-O Alliance double set

Double-sided workbench with two lateral aluminium frames. The workbench is supplied in a set with double lower slat, double-sided perforated panel, double main shelf and two lighting units.

- Each tabletop load capacity: 200 kg

4 AL-O/D Alliance additional double set

Double-sided workbench with one lateral aluminium frame to be attached to main Alliance double workbench. The workbench is supplied in a set with double lower slat, double-sided perforated panel, double main shelf and two lighting units.

- Each tabletop load capacity: 200 kg

5 AL-PO/1 Additional shelf

Additional shelf for Alliance series workbenches.

- 2 versions: 30 cm depth and 40 cm depth
- Load capacity: 100 kg
- Height adjustment above tabletop: 1000 - 1850 mm.

6 AL-O-PO/1 Additional double shelf

Additional double shelf for double Alliance series workbenches.

- 2 versions: 30 cm depth and 40 cm depth from each side
- Load capacity: 100 kg
- Height adjustment above tabletop: 1000 - 1850 mm.

CODE ↓	DIMENSIONS
AL-12-7 / AL/D-12-7	1200x700 mm
AL-15-7 / AL/D-15-7	1500x700 mm
AL-18-7 / AL/D-18-7	1800x700 mm
AL-O-12-7 / AL-O/D-12-7	2*(1200x700) mm
AL-O-15-7 / AL-O/D-15-7	2*(1500x700) mm
AL-O-18-7 / AL-O/D-18-7	2*(1800x700) mm

Standard Alliance workbenches are powder-coated in dark grey color (RAL 7012) for lower steel modules and light grey color (RAL 7035) for tabletops and shelves.

Alliance series workbenches are supplied in a set with lower cleat, perforated panel, main shelf and lighting.

7 DL/N Under-shelf local LED lighting

Additional lighting can be mounted under the main shelf or attached to perforated panel. Suitable for any workbench equipped with upper modules. It provides uniform illumination of the working area central zone.

- 2 versions: 60 cm length and 90 cm length
- Light Source: LED lamps (30 pcs. for DL/N-6 and 45 pcs. for DL/N-9)
- Angle adjustment $\pm 60^\circ$
- Color temperature 4700 - 5300 K.
- Material of diffuser - 2mm thick opal acryl

Provides at least 1000 lux illuminance at 1000 mm distance from the light source.

8 AL-RK Bin rail

Aluminum rail for bin storage placed along workbench length.

- Load capacity: 10 kg

9 AL-O-RK Double bin rail

Double aluminum rail for bin storage placed along workbench length.

- Load capacity for each side: 10 kg

10 AL-EP Power panel

Basic configuration consists of 4 sockets placed in aluminium case with protective contact and 3 m cable. Panel can be equipped with additional sockets, earth leakage circuit breaker, automatic fuse and a phone jack.

- Nominal load capacity: 10 A
- Grounding cord cross-section: 0.75 mm

11 AL-O-EP Double power panel

Basic configuration consists of 2 aluminium cases, each with 4 sockets with protective contact and 3 m cable. Panel can be equipped with additional sockets, earth leakage circuit breaker, automatic fuse and a phone jack.

- Nominal load capacity each: 10 A

12 TP-01/P, TP-02/P Optional drawer units

Storage solution for tools and components, no space on floor required.

Dimensions:

- TP-01/P: 490 x 354 x 580 mm
- TP-02/P: 490 x 233 x 580 mm

ALLIANCE AUTOMATIC WORKBENCHES



Alliance automatic workbenches are distinguished by elegant design, advanced ergonomics and motorized worktop adjustment system, performed by electric drive and simple control unit. ALLIANCE Automatic allows setting tabletop height by pressing a button, which is indispensable in certain working processes.

CODE ↓	DIMENSIONS
AL/A-12	1200x700 mm
AL/A-15	1500x700 mm
AL/A-18	1800x700 mm

Alliance automatic workbenches are supplied in a set with adjustment mechanism, lower slat, perforated panel, main shelf, lighting and power panel.

- Possible automatic tabletop height adjustment limits (stroke length): 250 mm.
- Automatic height adjustment 700-950 mm from floor
- Automatic height adjustment speed: 3 mm per second
- Load capacity: 200 kg

Alliance automatic workbenches allow further extensions:

1 AL-A-PO/1 Additional shelf

Additional shelf for Alliance automatic series workbenches.

- 30 cm depth
- Load capacity: 100 kg
- Height adjustment above tabletop: 1000 - 1850 mm.

2 DL/N Under-shelf local lighting

Additional lighting can be mounted under the main shelf or attached to perforated panel. Suitable for any workbench series unit equipped with upper modules. It provides uniform illumination of the working area central zone.

- 2 versions: 60 cm length and 90 cm length
- Light Source: LED lamps (30 pcs. for DL/N-6 and 45 pcs. for DL/N-9)
- Angle adjustment $\pm 60^\circ$
- Color temperature 4700 - 5300 K.
- Material of diffuser – 2mm thick opal acryl

Provides at least 1000 lux illuminance at 1000 mm distance from the light source.



All ALLIANCE AUTOMATIC series workbenches and shelves are bicolored by default except for DL/N lighting unit that can be ordered in dark grey (RAL 7012) and light grey (RAL 7035) color.

When ordering, please mention whether ESD or technical version required

CLASSIC SERIES WORKBENCHES

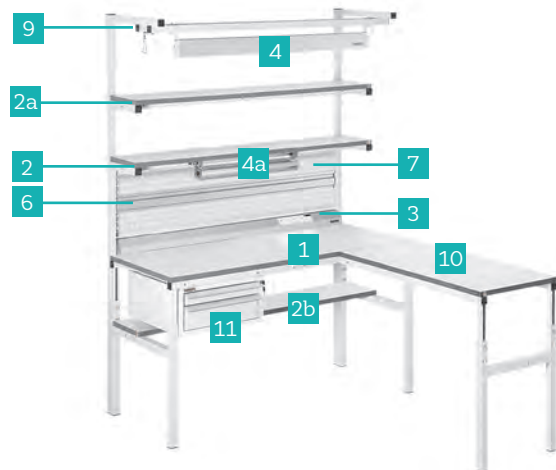
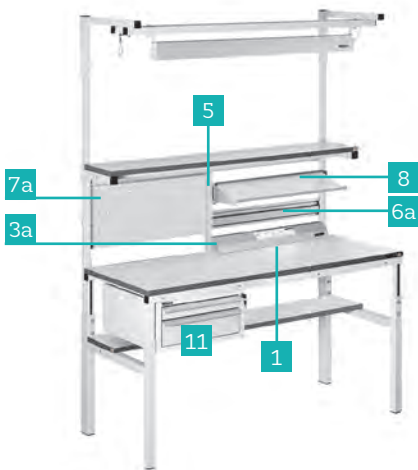

1 SR Classic Workbench

These workbenches can be placed in a line to make a common working area with no gaps. Universal design allows fitting out the workplace with additional equipment and drawer units.

Height adjustment: 650 - 950 mm

Load capacity: 300 kg

Temperature resistance: 300 °C

2 PO Main shelf

Rear racks included.

- 2 versions: 30 cm depth and 40 cm depth
- Height adjustment: 1000 - 1800 mm
- Load capacity: 50 kg

2a PO/1 Additional shelf

Requires PO Main shelf to be installed.

- 2 versions: 30 cm depth and 40 cm depth
- Height adjustment: 1100 - 1800 mm
- Load capacity: 50 kg

2b PO/2 Underneath shelf

Not compatible with TP-01/P Optional drawer unit.

- 2 versions: 30 cm depth and 40 cm depth
- Load capacity: 100 kg

3 EP Power panel

3a ½EP Power panel

Basic configuration consists of 4 sockets placed in aluminium case with protective contact and 3 m cable. Panel can be equipped with additional sockets, earth leakage circuit breaker, automatic fuse and a phone jack.

- Nominal load capacity: 10 A
- Grounding cord cross-section: 0.75 mm

4 DL/A Workbench lighting

DL/A Workbench lighting is placed in an aluminum case with 2 energy-efficient luminescent 54 W lamps, light direction regulation and shadowless reflector provided. Quick switching on without shimmering, no strobing freeze.

- Length: 1200 mm
- Height adjustable
- Illuminance at 1000 mm distance:
 - 1200 lux central
 - 800 lux peripheral

4a DL/N Under-shelf local lighting

Additional lighting can be mounted under the main shelf or attached to perforated panel. Suitable for any workbench series unit equipped with upper modules. It provides uniform illumination of the working area central zone.

- 2 versions: 60 cm length and 90 cm length
- Light Source: LED lamps (30 pcs. for DL/N-6 and 45 pcs. for DL/N-9)
- Angle adjustment ± 60°
- Color temperature 4700 - 5300 K.
- Material of diffuser – 2mm thick opal acryl

Provides at least 1000 lux illuminance at 1000 mm distance from the light source.

CODE ↓	DIMENSIONS
SR-12-7	1200x700 mm
SR-15-7	1500x700 mm
SR-18-7	1800x700 mm
SR-12-9	1200x900 mm
SR-15-9	1500x900 mm
SR-18-9	1800x900 mm

5 Middle upright for all ½ items

Required to hold any ½ item. 3 sizes to match standard workbench width.

6 RK Bin rail

6a ½RK Bin rail

Aluminum rail for bin storage placed along workbench length.

- Load capacity: 10 kg

7 PFP Perforated panel

7a ½PFP Perforated panel

Panel can be equipped with different holders for additional equipment and tools storage.

8 PN Sloped shelf

Half-sized shelf. Angle adjustment provides comfort monitoring of working equipment.

- Load capacity: 50 kg

9 IP Cantilever

It was designed for easy-to-reach attaching of drawings, lighting and instruments. IP Cantilever can be additionally equipped by retracing KL-1200 mechanism.

10 US-1 Corner workbench

- Dimensions: 1200x500 mm

11 TP-01/P, TP-02/P Optional drawer units

Storage solution for tools and components, no space on floor required. Dimensions:

- TP-01/P: 490x354x580 mm
- TP-02/P: 490x233x580 mm

When ordering, please mention whether ESD or technical version, and whether dark grey RAL 7012 or light grey RAL 7035 color required.



COMFORT SERIES WORKBENCHES

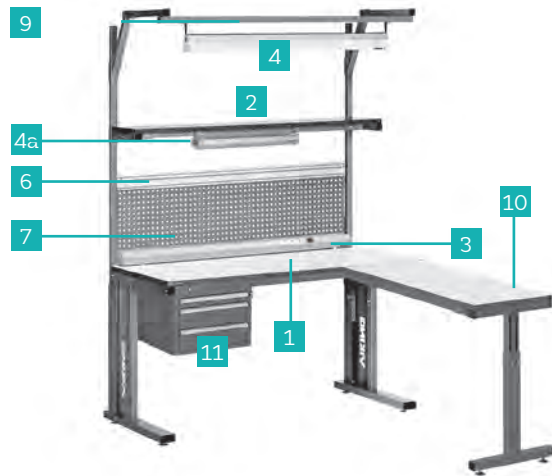
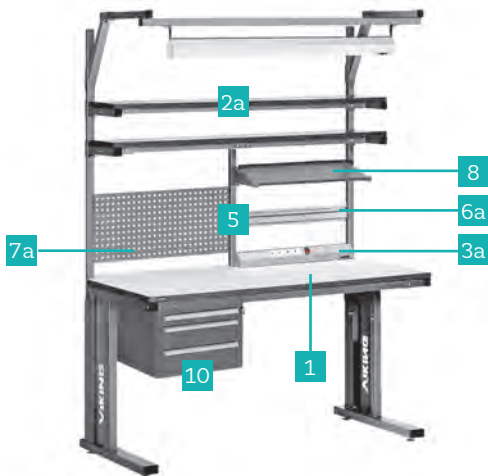

1 SR COMFORT Workbench

These workbenches offer advanced ergonomic characteristics.

- Height adjustment: 800 - 950 mm
- Load capacity: 200 kg
- Heat resistance: 300 °C

2 PO Main shelf

Rear racks included.

- 2 versions: 30 cm depth and 40 cm depth
- Height adjustment: 1000 - 1850 mm
- Load capacity: 50 kg

2a PO/1 Additional shelf

Requires PO Main shelf to be installed.

- 2 versions: 30 cm depth and 40 cm depth
- Height adjustment: 1100 - 1850 mm
- Load capacity: 50 kg

3 EP Power panel

3a ½ EP Power panel

Basic configuration consists of 4 sockets placed in aluminium case with protective contact and 3 m cable. Panel can be equipped with additional sockets, earth leakage circuit breaker, automatic fuse and a phone jack.

- Nominal load capacity: 10 A
- Grounding cord cross-section: 0.75 mm

4 DL/A COMFORT Workbench lighting

DL/A Comfort Workbench lighting is placed in an aluminum case with 2 energy-efficient luminescent 54 W lamps, light direction regulation and shadowless reflector provided. Quick switching on without shimmering, no strobe effect.

- Length: 1200 mm
- Height adjustable
- Illuminance at 1000 mm distance:
 - 1200 lux central
 - 800 lux peripheral

4a DL/N Under-shelf local lighting

Additional lighting can be mounted under the main shelf or attached to perforated panel. Suitable for any workbench series unit equipped with upper modules. It provides uniform illumination of the working area central zone.

- 2 versions: 60 cm length and 90 cm length
- Light Source: LED lamps (30 pcs. for DL/N-6 and 45 pcs. for DL/N-9)
- Angle adjustment ± 60°
- Color temperature 4700 - 5300 K.
- Material of diffuser – 2mm thick opal acryl

Provides at least 1000 lux illuminance at 1000 mm distance from the light source.

CODE ↓

DIMENSIONS

SR-12-7 Comfort	1200x700 mm
SR-15-7 Comfort	1500x700 mm
SR-18-7 Comfort	1800x700 mm

5 Middle upright for all ½ items

Required to hold any ½ item. 3 sizes to match standard workbench width.

6 RK Bin rail

6a ½ RK Bin rail

Aluminum rail for bin storage placed along workbench length.

- Load capacity: 10 kg

7 PFP Perforated pane

7a ½ PFP Perforated panel

Panel can be equipped by different holders for additional equipment and tools storage.

8 PN Sloped shelf

Half-sized shelf. Angle adjustment provides comfort monitoring of working equipment.

- Load capacity: 50 kg

9 IP Cantilever

It was designed for easy-to-reach attaching of drawings, lighting and instruments. IP Cantilever can be additionally equipped by retracing KL-1200 mechanism.

10 US-1 COMFORT Corner workbench

Dimensions: 1200x500 mm.

11 TP-01/P, TP-02/P Optional drawer units

Storage solution for tools and components, no space on floor required. Dimensions:

- TP-01/P: 490x354x580 mm
- TP-02/P: 490x233x580 mm

When ordering, please mention whether ESD or technical version, and whether dark grey RAL 7012 or light grey RAL 7035 color required.



CONSTANT SERIES WORKBENCHES

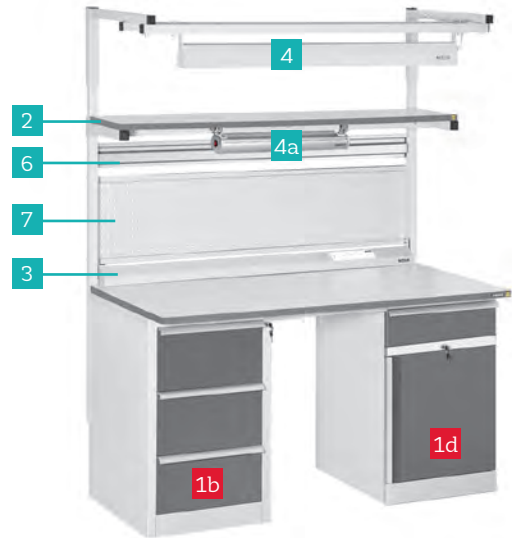
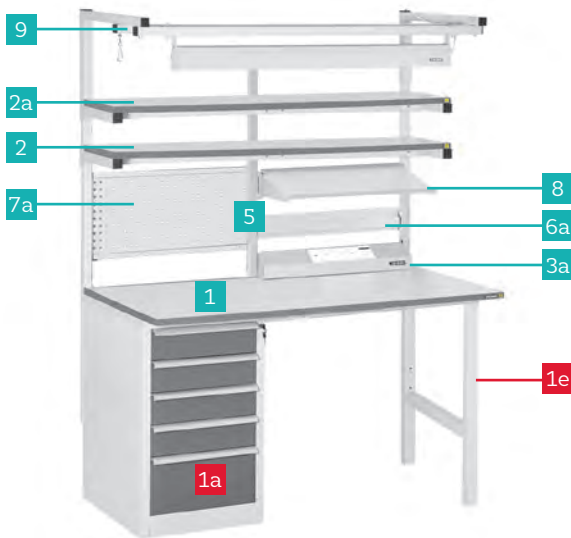

1 SR CONSTANT Workbenches

These workbenches cannot be height-adjusted.

- Tabletop height: 825 mm
- Load capacity: 300 kg

As a support, Constant workbenches can have:

- 1a Cabinet unit with 5 drawers on telescopic runners and a lock (+DR-05)
- 1b Cabinet unit with 3 bigger drawers on telescopic runners and a lock (+DR-03)
- 1c Cabinet with 2 shelves and a lock (+ TMB-01)
- 1d Cabinet with 1 drawer and 2 shelves in a locked section (+ TMB-02)
- 1e Legs

Supports can be used in any combination except for 1200 mm width workbenches that should have legs as one support. **Cabinets and drawer units used as worktop supports are bicolored by default.**

2 PO Main shelf

Rear racks included.

- 2 versions: 30 cm depth and 40 cm depth
- Height adjustment: 1000 - 1850 mm
- Load capacity: 50 kg

2a PO/1 Additional shelf

Requires PO Main shelf to be installed.

- 2 versions: 30 cm depth and 40 cm depth
- Height adjustment: 1100 - 1800 mm
- Load capacity: 50 kg

3 EP Power panel

3a ½ EP Power panel

Basic configuration consists of 4 sockets placed in an aluminium case with protective contact and 3 m cable. Panel can be equipped with additional sockets, earth leakage circuit breaker, automatic fuse and a phone jack.

- Nominal load capacity: 10 A
- Grounding cord cross-section: 0.75 mm

4 DL/A Workbench lighting

DL/A Workbench lighting is placed in an aluminum case with 2 energy-efficient luminescent 54 W lamps, light direction regulation and shadowless reflector provided. Quick switching on without shimmering, no strobe effect.

- Length: 1200 mm
- Height adjustable
- Illuminance at 1000 mm distance: 1200 lux central and 800 lux peripheral

4a DL/N Under-shelf local lighting

Additional lighting can be mounted under the main shelf or attached to perforated panel. Suitable for any workbench series unit equipped with upper modules. It provides uniform illumination of the working area central zone.

- 2 versions: 60 cm length and 90 cm length
- Light Source: LED lamps (30 pcs. for DL/N-6 and 45 pcs. for DL/N-9)
- Angle adjustment ± 60°
- Color temperature 4700 - 5300 K.
- Material of diffuser – 2mm thick opal acryl

Provides at least 1000 lux illuminance at 1000 mm distance from the light source.

CODE ↓	DIMENSIONS
SR-12-7+DR-05 SR-12-7+DR-03 SR-12-7+TMB-01 SR-12-7+TMB-02	1200×700 mm
SR-15-7+DR-05 SR-15-7+TMB-02 SR-15-7+DR-05+DR-05 SR-15-7+DR-03+TMB-02 and etc.	1500×700 mm
SR-18-7+DR-03 SR-18-7+TMB-01 SR-18-7+TMB-01+TMB-02 SR-18-7+DR-03+TMB-01 and etc.	1800×700 mm

5 Middle upright for all ½ items

Required to hold any ½ item. 3 sizes to match standard workbench width.

6 RK Bin rail

6a ½ RK Bin rail

Aluminum rail for bin storage placed along workbench length.

- Load capacity: 10 kg

7 PFP Perforated panel

7a ½ PFP Perforated panel

The panel can be equipped by different holders for additional equipment and tools storage.

8 PN Sloped shelf

Half-sized shelf. Angle adjustment provides comfort monitoring of working equipment.

- Load capacity: 50 kg

9 IP Cantilever

Cantilever is designed for easy-to-reach attaching of drawings, lighting and instruments. Cantilever can be additionally equipped by re-tracing KL-1200 mechanism.



When ordering, please mention whether ESD or technical version, and whether dark grey RAL 7012 or light grey RAL 7035 color required.

OSTROV SERIES WORKBENCHES

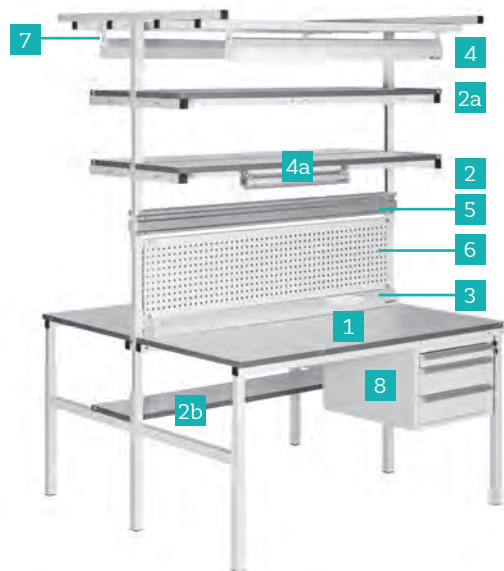

1 SO Ostrov Workbench

Double-sided workbench allow effective use of space. Basic configuration includes 300 mm shelves for each workplace

- Height adjustment: 655 - 950 mm
- Load capacity: 300 kg
- Temperature resistance: 300 °C

2a PO-O Additional shelf

Height adjustment: 1100 - 1800 mm

- 2 versions: 30 cm depth and 40 cm depth from each side
- Load capacity: 50 kg

2b PO/2 Underneath shelf

Not compatible with optional TP-01/P drawer.

- 2 versions: 30 cm depth and 40 cm depth
- Load capacity: 100 kg

3 EP-O Power panels

Basic configuration consists of 2 aluminium cases each with 4 sockets with protective contacts and 3 m cables. Panels can be equipped with additional sockets, earth leakage circuit breakers, automatic fuses and phone jacks.

- Nominal load capacity: 10 A
- Grounding cord cross-section: 0.75 mm

4 DL-O/A Workbench lighting

DL-O/A Workbench lightings are placed in aluminum cases, each with 2 energy-efficient luminescent 54 W lamps, light direction regulation and shadowless reflector. Quick switching on without shimmering, no strobing freeze.

- Length: 1200 mm
- Height adjustable
- Illuminance at 1000 mm distance: 1200 lux central and 800 lux peripheral

4a DL/N Under-shelf local lighting

Additional lighting can be mounted under the main shelf or attached to perforated panel. Suitable for any workbench series unit equipped with upper modules. It provides uniform illumination of the working area central zone.

- 2 versions: 60 cm length and 90 cm length
- Light Source: LED lamps (30 pcs. for DL/N-6 and 45 pcs. for DL/N-9)
- Angle adjustment $\pm 60^\circ$
- Color temperature 4700 - 5300 K.
- Material of diffuser – 2mm thick opal acryl

Provides at least 1000 lux illuminance at 1000 mm distance from the light source.

CODE ↓	DIMENSIONS
SO-12-7	2x(1200x700) mm
SO-15-7	2x(1500x700) mm
SO-18-7	2x(1800x700) mm



5 Double bin rail

Double aluminum rail for storage placed along workbench length.

- Load capacity: 10 kg

6 Double perforated panel

The panel can be equipped by different holders for additional equipment and tools storage.

7 IP Cantilever

It was designed for easy-to-reach attaching of drawings, lighting and instruments. IP Cantilever can be additionally equipped by retracting KL-1200 mechanism.

8 TP-01/P, TP-02/P Optional drawer units

Storage solution for tools and components, no space on floor required. Dimensions:

- TP-01/P: 490x354x580 mm
- TP-02/P: 490x233x580 mm

When ordering, please mention whether ESD or technical version, and whether dark grey RAL 7012 or light grey RAL 7035 color required.



VERSTAK SERIES HEAVY DUTY WORKBENCHES

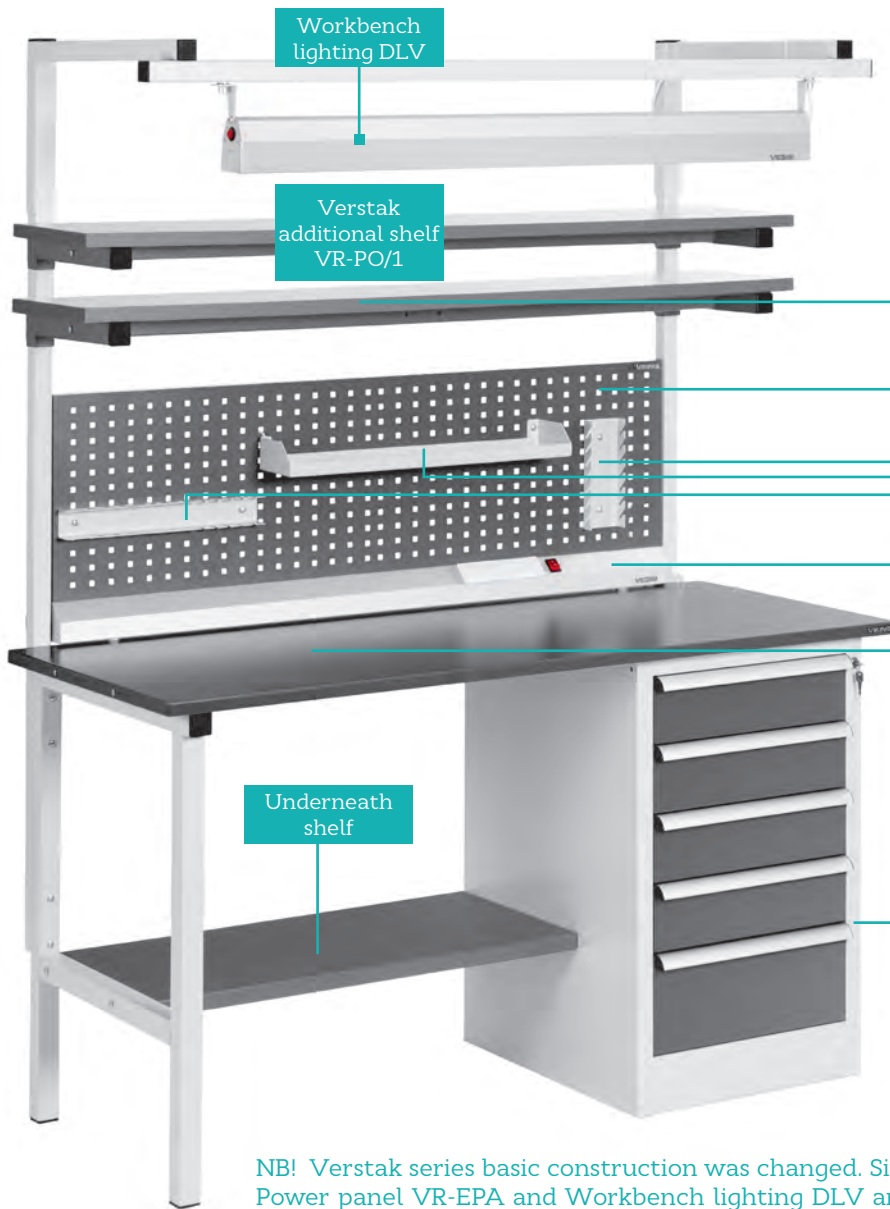

VERSTAK series offer module workbenches of heightened rigidity and durability with distributed load capacity of over 500 kg. These workbenches offered only in technical / non-antistatic version.

Workbench lighting DLV

Verstak additional shelf VR-PO/1

Verstak main shelf VR-PO

Perforated panel PRV

Holders

Power panel VR-EP

Tabletop

Underneath shelf

Maximum functionality is achieved by a range of tabletops, supports and additional equipment. Standard width is 630 mm and height - 800 mm plus tabletop's thickness.

Drawer unit

NB! Verstak series basic construction was changed. Since now Perforated panel PRV, Power panel VR-EPA and Workbench lighting DLV are mounted in a set with Main shelf or should be ordered separately if Main shelf isn't required. Perforated panel is supplied in a set with small rear racks thus can be ordered separately from other upper modules.

There are 4 types of tabletops

Type 1	21 mm thick plywood with light grey plastic edges.
Type 2	21 mm thick plywood covered by 2 mm dark grey metal sheet, the latter is bent over edges.
Type 3	21 mm thick plywood with light grey plastic edges covered by 6 mm dark grey metal sheet.
Type 4	6 mm thick dark grey metal sheet.



Type 1



Type 2



Type 3



Type 4

There are 5 standard types of worktop supports

- 1a Cabinet unit with 5 drawers on telescopic runners and a lock (+DR-05)
- 1b Cabinet unit with 3 bigger drawers on telescopic runners and a lock (+DR-03)
- 1c Cabinet with 2 shelves and a lock (+ TMB-01)
- 1d Cabinet with 1 drawer and 2 shelves in a locked section (+ TMB-02)
- 1e Legs



These supports can be combined, but 1200 mm width Verstak workbenches should have legs as one support.

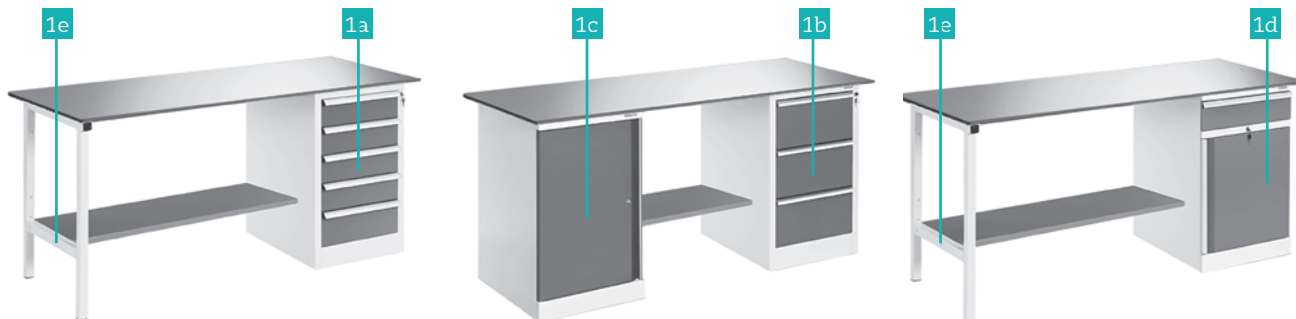

	VR: Verstak with a drawer unit (DR-03 or DR-05)	VR-12+DR-03/No.	VR-12+DR-05/No.	1200x630 mm
		VR-15+DR-03/No.	VR-15+DR-05/No.	1500x630 mm
		VR-18+DR-03/No.	VR-18+DR-05/No.	1800x630 mm
	VR: Verstak with a cabinet (TMB-01 or TMB-02)	VR-12+TMB-01/No.	VR-12+TMB-02/No.	1200x630 mm
		VR-15+TMB-01/No.	VR-15+TMB-02/No.	1500x630 mm
		VR-18+TMB-01/No.	VR-18+TMB-02/No.	1800x630 mm
	VR: Verstak with different combinations of cabinets (TMB-01, TMB-02) and drawer units (DR-03, DR-05)	VR-15+DR-05+DR-05/No. VR-15+DR-03+DR-05/No. VR-15+TMB-01+TMB-02/No. VR-15+DR-05+TMB-01/No. VR-15+DR-03+TMB-02/No.	VR-15+DR-03+DR-03/No. VR-15+TMB-01+TMB-01/No. VR-15+TMB-02+TMB-02/No. VR-15+DR-05+TMB-02/No. VR-15+DR-03+TMB-01/No.	1500x630 mm
		VR-18+DR-05+DR-05/No. VR-18+DR-03+DR-05/No. VR-18+TMB-01+TMB-02/No. VR-18+DR-05+TMB-01/No. VR-18+DR-03+TMB-02/No.	VR-18+DR-03+DR-03/No. VR-18+TMB-01+TMB-01/No. VR-18+TMB-02+TMB-02/No. VR-18+DR-05+TMB-02/No. VR-18+DR-03+TMB-01/No.	1800x630 mm

Note: No. in the workbench code corresponds to tabletop type (1, 2, 3 or 4). For example, VR-12+TMB-01/3.

PRV: Perforated panel for Verstak workbench (small shelf and 2 holders included)	PRV-12	for 1200 mm width workbenches
	PRV-15	for 1500 mm width workbenches
	PRV-18	for 1800 mm width workbenches
DLV: Workbench lighting. Requires Main shelf or Rear Racks to be installed	DLV-12	for 1200 mm width workbenches
	DLV-15	for 1500 mm width workbenches
	DLV-18	for 1800 mm width workbenches
VR-PO: Verstak main shelf	VR-PO-12	1200x300 mm
	VR-PO-15	1500x300 mm
	VR-PO-18	1800x300 mm
VR-PO/1: Verstak additional shelf. Requires Main shelf.	VR-PO/1-12	1200x300 mm
	VR-PO/1-15	1500x300 mm
	VR-PO/1-18	1800x300 mm
VR-EP: Verstak power panel. Requires Main shelf or Rear Racks or PRV.	VR-EP-12	for 1200 mm width workbenches
	VR-EP-15	for 1500 mm width workbenches
	VR-EP-18	for 1800 mm width workbenches
DL/N: Under-shelf local lighting. Requires Main shelf or PRV	DL/N-6	600 mm
	DL/N-9	900 mm
Rear racks	KZS	1500 mm

UNIVERSAL WORKBENCHES

SU Universal workbenches



The simplest and one of the cheapest workbench in our product range. UNIVERSAL workbenches do not allow any upper extension, but can be placed in a line with no gaps. 700 mm and 900 mm depth SU workbenches can be equipped with TP-01/P and TP-02/P Optional drawer units

CODE ↓	DIMENSIONS
SU-12-5	1200 x 500 mm
SU-12-7	1200 x 700 mm
SU-12-9	1200 x 900 mm
SU-15-5	1500 x 500 mm
SU-15-7	1500 x 700 mm
SU-15-9	1500 x 900 mm
SU-18-5	1800 x 500 mm
SU-18-7	1800 x 700 mm
SU-18-9	1800 x 900 mm

SPECIALIZED WORKBENCHES

KS Movable computer equipment workbench



Space-saving movable workbench for computer and measurement equipment storage and transportation.

Movable workbench for computer and measurement equipment is equipped with four 50 mm casters, 2 of which are with **brakes**.

Standard tabletop size 900x700 mm, tabletop height adjustment: 650 - 1000 mm.

Movable workbench for computer and measurement equipment has two shelves: 900x300 mm upper shelf and 900x400 mm lower shelf, both with 70 kg load capacity and a **keyboard support**.

When ordering, please mention whether ESD or technical version, and whether dark grey RAL 7012 or light grey RAL 7035 color required.

USS-SU Corner connecting workbench



Corner connecting workbench is used to build up inseparable working area being a connector for two standard Classic, Comfort or Constant workbenches put at right angle. Increased depth of tabletop and load capacity of 200 kg allows storing and using heavy or bulky equipment.

Corner connecting workbench is produced in 2 sizes to match 700 mm depth workbenches and 900 mm depth workbenches. Perforated panel, main and additional shelves, lighting units and power panels can be mounted to corner connecting workbench on request.

CODE ↓	DIMENSIONS
USS-SU-7	A x B x C 700 x 1050 x 500 mm
USS-SU-9	A x B x C 900 x 1250 x 500 mm

When ordering, please mention whether ESD or technical version, and whether dark grey RAL 7012 or light grey RAL 7035 color required.

SPECIALIZED workbenches for optical fiber handling



2



Two versions: 1 Workbench set, 2 single workbench.

CODE ↓	DIMENSIONS
Set SOV-12-7 ESD	1200 x 700
Set SOV-15-7 ESD	1500 x 700
Set SOV-18-7 ESD	1800 x 700
SOV-12-7 ESD	1200 x 700
SOV-15-7 ESD	1500 x 700
SOV-18-7 ESD	1800 x 700

Workbench's worktop and main shelf are covered with black ESD plastic (RAL 9005) to provide convenience for optical fibers works. Set is supplied with main shelf and lighting, single workbench is supplied separately. Available only in ESD version.

WIRE HARNESS WORKBENCH

SR-ZHG Wire harness workbench

Wire harness workbench with 0° to 80° angle adjustable worktop and special horizontal 13×6 mm perforation, which allows fastening various types of wires and bundles. Worktop angle adjustment and fixation is performed by side clamping handles.

Workbench supports unit dimensions: 1425×690 mm.
Perforated worktop available in 3 versions (width×height):

- 1500×1400 mm,
- 1800×1400 mm
- 2000×1400 mm.

Workbench height:

- in horizontal position of the worktop - 800 mm
- in vertical position of the worktop - 1760 mm

Maximum load capacity: 70 kg.

Available only in technical version. Supplied in a set with casters



WIRE HARNESS WORKBENCH ACCESSORIES

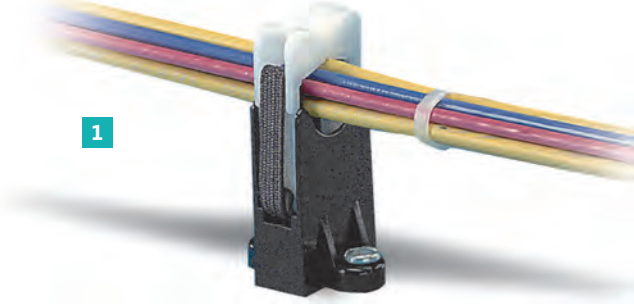

1



2



3



4

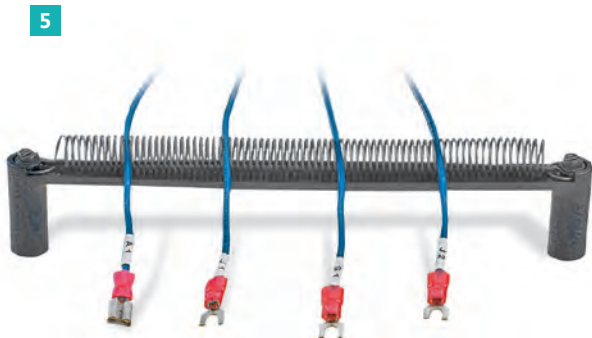

5

Different types of holders, retainers, corner posts and wire breakout systems which help to hold wires and form bundles on wire harness workbench.

They can be placed anywhere on wire harness worktop and attached to it through a special 13×6 mm horizontal perforation by 3,5×16 screws.

CODE	DIMENSIONS (WXHxD)	MAX. BUNDLE DIAMETER	COMMENTS
1 Harness elastic retainer			
RER.75-S6-X	30×56.1× ×28.4 mm	19 mm	Cable bundles are formed as cable bundles are inserted. Completed bundles can be easily removed
2 Harness replacement elastic band for RER.75-S6-X.			
RER.75E-X			The elastic band is replaceable
2 Harness elastic retainer			
RER2.0-S6-X	33.3×100.2× ×71.4 mm	50.8 mm	Cable bundles are formed as cable bundles are inserted. Completed bundles can be easily removed
3 Harness replacement elastic band for RER2.0-S6-XX			
RER2.0E-X			The elastic band is replaceable
3 Low profile elastic retainer			
ER.5-E4-X	49.8×25.4× ×14.2 mm	12.7 mm	Cable bundles are formed as cable bundles are inserted. Completed bundles can be easily removed
ER1.25-E4-X	73.7×50.8× ×24.1 mm	31.8 mm	
4 Corner post			
High profile corner post			
CPH.75-S8-X	22.9×47.8× ×40.8 mm	19 mm	Designed to pre-form tight bundles at harness corners and breakouts. Top arm rotates upward for easy removal of completed harness
Low profile corner post			
CPL.75-S8-X	22.4×27.4× ×38.6	19 mm	

5 Spring wire breakout system

Harness board spring and spring holder holds wire ends secure while harness is being fabricated. Wires simply pull out from spring when harness is removed

CODE	SPAN BETWEEN FASTENINGS (LENGTH)
SHH1-S8-X	47.0 mm
SHH3-S8-X	172.7 mm
PBSC3-X	76.2 mm
PBSC12-X	304.8 mm

ALPHA UNIVERSAL WORKBENCH



Simplified Alpha series workbench without upper modules

Alpha universal workbenches allow several extensions:

- Optional drawer unit
- Box with protective plastic fibers and power panel

1 Box with protective plastic fibers on box lid's edges

Metal box with power panel is mounted to the back side of ALHA universal workbench. The box's lid is covered with plastic fibers to protect power panel from dust and cuttings. Can be also used as a worktop extension which makes the workbench depth 180 mm more. Power panel consists of 8 sockets in an aluminium case with protective contact and 3 m cable. Nominal load capacity: 10 A. Available in technical and ESD versions

2 Optional drawer unit

Storage solution for tools and components, no space on floor required. Equipped with central lock

All Alpha universal modules are bicolored by default except for TP-01/P and TP-02/P optional drawer units that can be ordered in dark grey (RAL 7012) and light grey (RAL 7035) color. When ordering, please mention whether ESD or technical version required.

CUSTOMIZED LAYOUTS

We are pleased to offer customized layouts based on our clients' individual requirements and projects. One can change size, shapes, add necessary elements to any particular module. Those previously produced can be ordered again through our website **Customized order** feedback form. **Minimum order quantity for customized layouts – 5 pieces.**

EM-SR-14 Workbench for electrical installation operations



SHL-1 ESD cells wardrobe



ALF-N ALPHA series workbench with 3 aluminium supports and customized shape worktop



TTL-N Laboratory equipment transportation cart



WORKPLACES ADDITIONAL EQUIPMENT, GROUNDING EQUIPMENT

PO-IP-12/15/18 Tabletop secondary structure

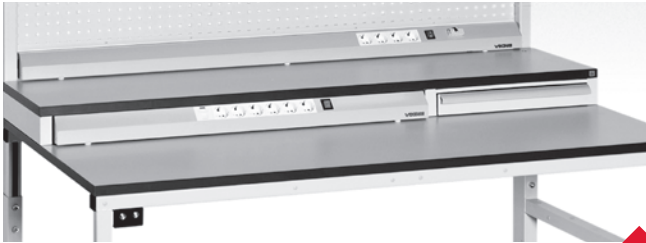

Tabletop secondary structure is equipped with additional power panel, the possibility of extension is provided: basic version includes four sockets and a switch, 2 sockets can be added for 1200 mm length item, 8 sockets can be added for 1500 mm length item and 13 sockets can be added for 1800 mm length item.

Power panel can also be equipped with additional sockets.

- Load capacity: 120 kg
- Dimensions: 1200/1500/1800x400x65 mm

PPK-02 Metal keyboard support



Telescoping metal support saves space on the tabletop.

Keyboard support is produced of powder coated steel and available in dark grey (RAL 7012) or light grey (RAL 7035) colors.

Keyboard support can be mounted to any workbench series which has enough space under the tabletop (minimum of 615 mm width and 383 mm depth is required).

- Dimensions 616x135x383mm, keyboard support inner dimensions: 245x505mm
- Load capacity: 30 kg

KL-1200 Retracing mechanism



Designed to suspend instruments and make them easy-to-reach. Cable tension depends on the weight of the instrument which should be in a 0.6 - 1.5 kg range.

EP Power Panel accessories

- single socket with grounding
- double socket with grounding
- 10 A automatic fuse
- 16 A automatic fuse
- circuit breaker (F362-16/2/0.01-A)
- automatic circuit breaker with power line disturbances suppression.

PPN-02 Footrest

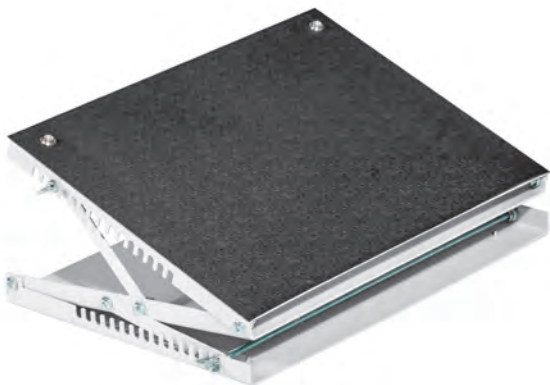

Footrest helps to provide workers with an ergonomically correct sitting position. PPN-02 footrest is equipped with height and angle adjustment mechanism. Dimensions: 400x300 mm.



PPCH-01 / PPCH-01/A Drafts holders



Adjustable drafts holder. Supplied in a set with 2 VIKING magnets. Requires PO Main shelf or Rear racks for SR series workbenches. Mounted to aluminium racks when used with Alpha or Alliance series workbenches.

- Load capacity: 15 kg
- Metal plate dimensions: 430×310 mm
- Rotary segments' length: 200 mm

PPM-03 / PPM-03/A Monitor supports



Adjustable support helps to save space on the tabletop. Requires PO Main shelf or Rear racks for SR series workbenches. Mounted to aluminium racks when used with Alpha or Alliance series workbenches.

- Load capacity: 15 kg
- Rotary segments' length: 200 mm

PPS-01 Movable computer case support



220x150x480 mm support helps to move the computer case around the area.

PPS-03 Suspended computer case support

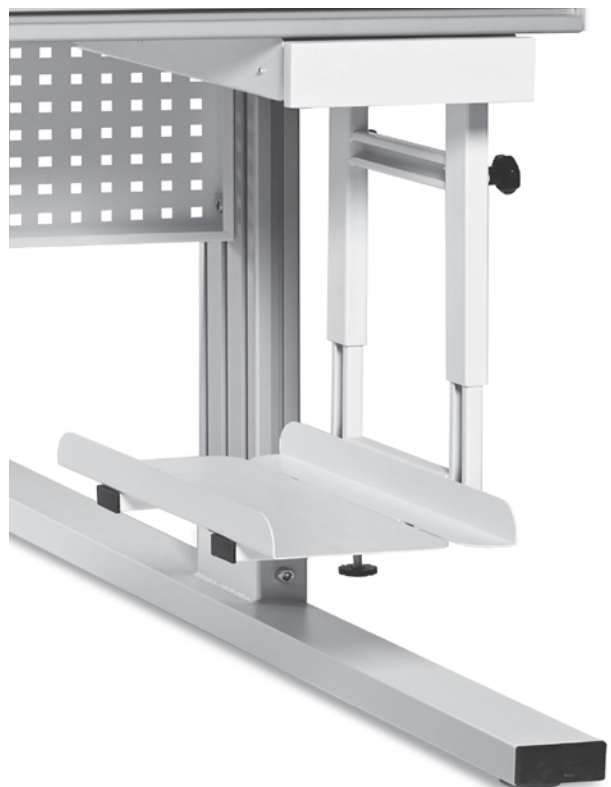

Dimensions (W×H×D): 265x460x460 mm. Suitable for any VIKING workbench.

ARK Bin rail



Aluminium rail can be installed wherever on the wall to hold attached storage bins.



DL/N Under-shelf local lighting

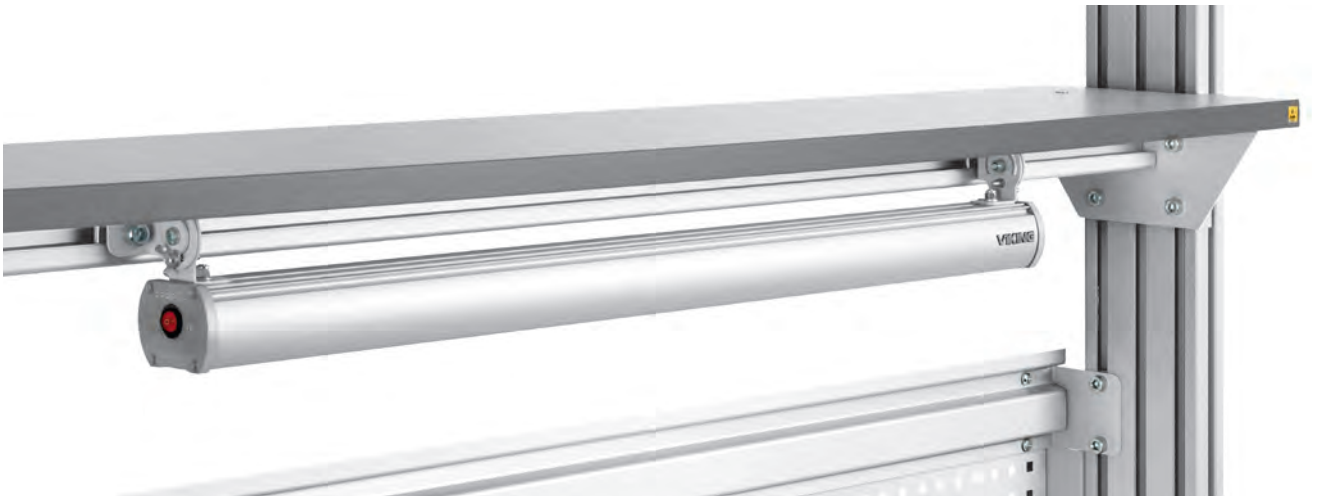

Additional lighting can be mounted under the main shelf or attached to perforated panel. Suitable for any workbench series unit equipped with upper modules. It provides uniform illumination of the working area central zone.

- 2 versions: 60 cm length and 90 cm length
- Light Source: LED lamps (30 pcs. for DL/N-6 and 45 pcs. for DL/N-9)
- Angle adjustment $\pm 60^\circ$
- Color temperature 4700 - 5300 K.
- Material of diffuser – 2mm thick opal acryl

Provides at least 1000 lux illuminance at 1000 mm distance from the light source.



PPT-01 Movable drawer unit support



Movable drawer unit support is an additional unit that helps to turn stationary drawer units and cabinets into movable one. It matches all standard cabinets (TMB-01 and TMB-02) and drawer units (DR-03, DR-05, DR-07 and DR-10/1). Four 50 mm casters, 2 of which are with brakes.

- Dimensions (W*H*D): 510x10x600 mm
- Load capacity: 350 kg



PO-ZHL/VR-PO-ZHL Sliding shutters shelf

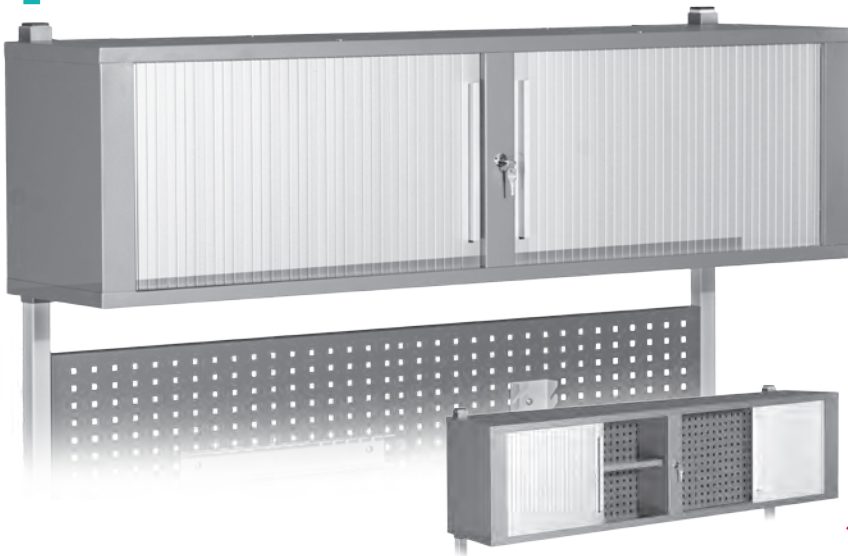

Additional shelf with sliding shutters can be mounted to any Classic or Constant (PO-ZHL) and Verstak (VR-PO-ZHL) series standard workbench which has Rear Racks. This additional shelf has two sliding shutters and a lock, which allows safe tools, equipment and documents storage.

PO-ZHL/VR-PO-ZHL Sliding shelf is produced in 3 standard sizes to match 1200 mm, 1500 mm and 1800 mm workbenches.

Dimensions (W×H×D):

- 1200×400×300 mm
- 1500×400×300 mm
- 1800×400×300 mm

Load capacity: 50 kg

PFP Perforated Panel accessories



	<p>K-01</p> <p>Hook for tweezers and equipment with small handles.</p> <p>Dimensions: 182x47x35 mm.</p>		<p>K-06</p> <p>Hooks for spanners.</p> <p>Dimensions: 150x190x45 mm</p>
	<p>K-02</p> <p>Hook for screwdrivers.</p> <p>Dimensions: 182x47x35 mm.</p>		<p>K-07</p> <p>Double hook for heavy instruments.</p> <p>Dimensions: 35x40x80 mm</p>
	<p>K-03</p> <p>Holder for pliers.</p> <p>Dimensions: 182x130x45 mm</p>		<p>K-08</p> <p>Tray for small components and bottles.</p> <p>Dimensions: 180x45x80 mm</p>
	<p>K-04</p> <p>Hook for tools.</p> <p>Dimensions: 182x45x23 mm</p>		<p>K-09</p> <p>Tray for A4-size papers.</p> <p>Dimensions: 310x45x220 mm</p>
	<p>K-05</p> <p>Holder for screwdrivers and 9-13 mm diameter drills.</p> <p>Dimensions: 180x100x30 mm</p>		<p>K-10</p> <p>A4-size papers holder.</p> <p>Dimensions: 240x280x25 mm.</p>

GROUNDING AND ADDITIONAL EQUIPMENT

VKG A-9400 Connecting plug for grounding cables



White connecting plug for grounding cables with 1 MOhm resistor

VKG A-3146 Grounding unit



Two 10 mm buttons ground table mats, wrist straps and devices via junction block.

VKG KH 4060, VKG KH 6090, VKG KH 12060 ESD mats



Fire-resistant and solder-resistant ESD mats. Supplied in a set with grounding cord and wrist strap.

- Antiglare matte surface
- Colors: blue, grey

CODE →	VKG KH 4060	VKG KH 6090	VKG KH 12060
Dimensions	400×600 mm	600×900 mm	1200×600 mm
Charge decay time	Less than 0,04 sec		
Typical resistance to ground	10 ⁵ ...10 ⁹ Ohm		

Antistatic Floor Mat TOROSTAT

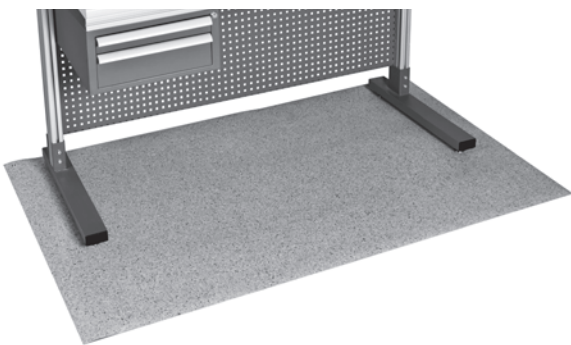

Double-layer anti-static floor mat 2.5 mm thick, abrasion resistant, sound-absorbing, non-flammable, thermally stable, dissipative top layer and conductive bottom layer: dripping time charge from 1000V to 50V in less than 0.5 seconds, the resistance of the ground – less than 100 MΩ, the combined resistance - less than 35 MΩ. Various dimensions: 150 mm × 200 to 1000 × 10000 mm.

VKG G-01 Universal grounding unit



Universal grounding unit compatible with most popular wrist strap connections : banana plug, GSGS, 4, 4.5, 7 and 10 mm snaps

- Grounds up to two single wrist straps
- 3 meter cord with eyelet
- No resistor

Should be mounted underneath tabletop and devices via junction block.

Wrist strap coil cords



1 MΩ resistor (Wrist strap connection side). Types of connections to fit most grounding systems worldwide. Female stud connections. Black color. Suitable to connect to a ground via VKG G-1

CODE	DESIGNATION	CORD LENGTH
30-560-0604	6' COIL CORD 4 mm / banana + crocodile clip	1.80 m
30-560-1004	12' COIL CORD 4 mm / banana + crocodile clip	3.00 m
30-560-0641	6' COIL CORD 4 mm / 10mm	1.80 m
30-560-0614	6' COIL CORD 4 mm / GSGS	1.80 m
30-560-0645	6' COIL CORD 4 mm / 4.5 mm	1.80 m
30-560-1014	10' COIL CORD 4 mm / GSGS	3.00 m

ESD Wrist straps



- VKG A-2202 conductive fabric wrist strap with 4 mm button and a 4 mm to 10 mm buttons cord
- VKG A-2202-0 conductive fabric wrist strap with 4 mm button
- VKG A-2210 conductive metal wrist strap with 4 mm button and a 4 mm to 10 mm buttons cord
- VKG A-2210-0 conductive metal wrist strap with 4 mm button

FULLY AUTOMATED TURNSTILE SYSTEM

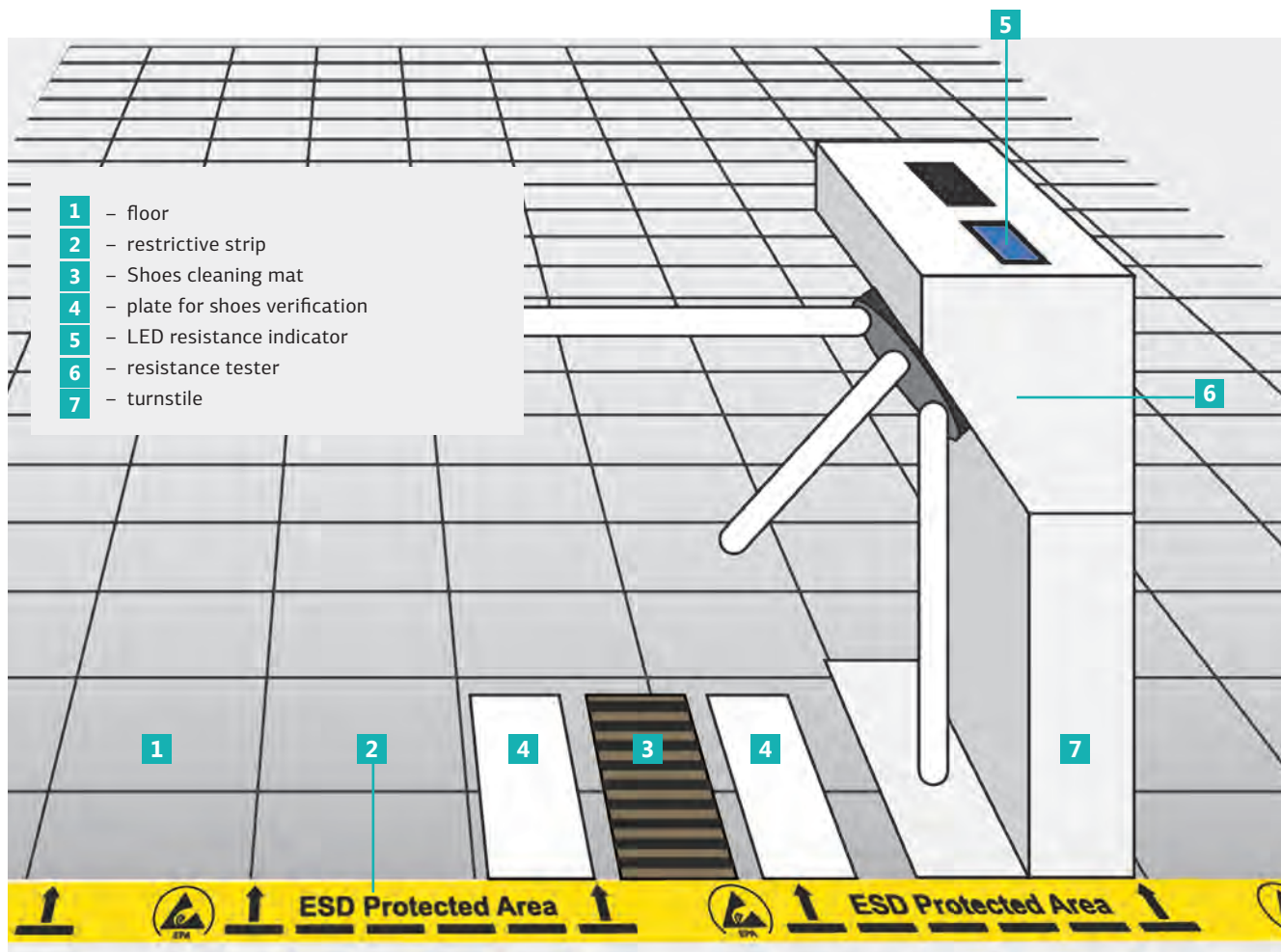

- 1 - floor
- 2 - restrictive strip
- 3 - Shoes cleaning mat
- 4 - plate for shoes verification
- 5 - LED resistance indicator
- 6 - resistance tester
- 7 - turnstile



Fully automated turnstile system. For companies who need to ensure that the operators cannot enter the EPA unless their wrist straps and footwear are compliant every day. The turnstile complies with ANSI/ESD S20/20 specification and ISO standards record keeping requirements. This system tests operators quickly and automatically and will generate reports and e-mail results simultaneously to the ESD coordinator.

- Turnstile Dimensions: 42 x 33 x 98 cm (W x D x H)
- Clear passage width: 51 cm
- Weight: 30 kg
- Values indications: Red and green led, different for each kind of equipment
- Voltage measurement: Measurement under permanent voltage of 20V +/- 5%
- Warning: acoustic signal and green arrow / red no entry logos
- Material: stainless steel Shoes electrodes
- Dimensions: 36 x 36 cm (L x W)
- Weight: 2.15 kg
- Features: Electrodes left foot and right foot
- Compliant with: RoHS Directive
 - 2006/95/CE Directive - low voltage
 - 2004/108/CE Directive - electromagnetic compatibility IEC 61340-5-1.
- 2 versions:
 - Automated turnstile system with footwear and wrist straps testers (61-200-3103).
 - "HIGH RANGE" automated turnstile system with card reader, footwear and wrist straps testers (61-200-3106).

DRAWER UNITS



Steel frame drawer units are designed for tools and components storage. Movable and stationary drawer units can be also used as additional workplaces. Steel frame drawer units are equipped with central lock and either 550 mm telescoping drawers or shelves. Movable units have 4 rubber casters, 2 of which are with brakes.

Drawers' inner dimensions for different types are

A – 400×45×505 mm **B** – 400×100×505 mm **C** – 400×160×505 mm. Load capacity per drawer 30 kg

Suspended and movable drawer units

DRAWER UNITS ↴	SUSPENDED		MOVABLE	
	TP-01/P	TP-02/P	TP-01/S	TP-02/S
Picture number	1	2	3	4
Dimensions (W×H×D):	490×354×580 mm	490×233×580 mm	490×580×580 mm	490×650×580 mm
Quantity of drawers	3	2	3	4
Drawers per unit	A	1	–	1
	B	2	1	2
	C	–	–	1
Weight (kg)	20	15	25	32

When ordering, please mention whether ESD or technical version, and whether dark grey RAL 7012 or light grey RAL 7035 color required.



Stationary cabinets and drawer units

Steel frame stationary cabinets and drawer units are designed for tools and components storage and can be also used as additional workplaces. All stationary cabinets and drawer units can be installed as worktop supports for Constant series workbenches and Verstak series heavy duty workbenches. All standard stationary cabinets and drawer units are bicolored by default. All cabinets and drawer units have /1 in code if standing separately (for example, DR-07/1) and indicated without additional number in code if used as Verstak or Constant series support (for example SR-12+DR-03).

CABINETS AND DRAWER UNITS ↴		STATIONARY CABINETS AND DRAWER UNITS			
		TMB-01/1	TMB-02/1	DR-03/1	DR-05/1
Picture number		5	6	7	8
Dimensions (W×H×D):		500×800×590 mm	500×800×590 mm	500×800×590 mm	500×800×590 mm
Quantity of drawers		2 shelves	1	3	5
Drawers per unit	B	-	1	-	4
	C	-	-	3	1
Weight (kg)		25	30	35	40

When ordering, please mention whether ESD or technical version required.

ENLARGED CABINETS AND DRAWER UNITS



ADDITIONAL EQUIPMENT FOR DRAWERS



Steel frame enlarged stationary drawer units are designed for tools and components storage; can be also used as additional workplaces.

DR-07/1 and DR-10/1 enlarged stationary drawer units are bicolored by default. For TMB-03/1 cabinet, please, mention whether dark grey RAL 7012 or light grey RAL 7035 color required. All cabinets and drawer units have /1 in code if standing separately (for example, DR-07/1).

Drawers' inner dimensions for different types are

A – 400×45×505 mm **B** – 400×100×505 mm **C** – 400×160×505 mm.

	DR-07/1	DR-10/1	TMB-03/1
Picture number	1	2	3
Dimensions (W×H×D):	500×1040×590 mm	500×1520×590 mm	540×1050×500 mm
Quantity of drawers	7	10	2 closable sections
Drawers types per unit	A	2	1
	B	2	5
	C	3	4
Weight (kg)	55	75	20

ALPHA CABINET

Drawer dividers sets

Dividers help to organize drawer internal space according to specific needs.

One can modify the space to many cells according to the number and dimensions of items needed to store: instruments, PCBs, mounting elements or other **items**.

1 D-10/A

Dividers for type A drawers (400×45×505 mm). The set consists of 4 longitudinal and 6 transversal dividers. Up to 35 different sized cells can be **organized**.

2 D-11/B

Dividers for type B drawers (400×100×505 mm). The set consists of 3 longitudinal and 4 big and 4 small profiled transversal dividers. Up to 10 different sized cells can be **organized**.

3 D-16/B

Dividers for type B drawers (400×100×505 mm). The set consists of 4 longitudinal and 6 medium and 6 small profiled transversal dividers. Up to 15 different sized cells can be **organized**.

4 KD/AB mat

ESD mat that should be ordered separately if drawers dividers set is being ordered for technical version cabinets. KD/AB mat is necessary to provide drawers dividers set stability and **reliability**.

5 Additional equipment for drawers – plastic ESD trays

ESD inserts for components and personal belongings convenience storage are made to match standard type A and type B drawers. ESD inserts are produced of 2,2 mm thick black dissipative polystyrene. Max temperature **60°C**.

2 versions:

- **V-01 ESD**, Antistatic inserts for type **A** standard drawers (400×45×505 mm). Insert contains 9 cells of different shape and dimensions: one 375×112 mm cell, four 182×112 mm cells, and four 86×112 mm cells.
- **V-02 ESD**, Antistatic inserts for type **B** standard drawers (400×100×505 mm). Insert contains 8 similar dimensions cells 112×182 mm each.

ALF-TMB-02 cabinet



Spacious metal cabinet for documents, folders and personal belongings; can be attached to workbench by bolts. Cabinet has 2 standard drawers and 2 sliding shelves, each has a perforated side wall, which can be placed on right or left side depending on further usage. ALF-TMB-02 cabinet only available in technical **version**.

- Dimensions: 445×1285×700 mm
- Distributed load capacity of each shelf: 30 kg
- Can be attached to any ALPHA series workbench from either side.



Shelves dividers for ALF-TMB-02 cabinet



1 D-7/ALF-2 Horizontal dividers

- 7 horizontal 335 mm length dividers help to organize cells for different small items.

2 D-4/ALF-2 Vertical dividers

- 4 vertical 240 × 290 mm dividers help to organize slots for folders and documents.



MOVABLE TABLES AND CARTS



1



2 3 4



5



1 PS-07 Comfort

2 3 4 PS-07, PS-10, PS-15 movable tables

Movable tables are used for tools and components storage and transportation. All movable tables are equipped with four 75 mm casters, 2 of which are with brakes. Height adjustment: 650 - 950 mm.

CODE	PS-07 COMFORT	PS-07	PS-10	PS-15
Picture number	1	2	3	4
Load capacity per surface (kg)	100 kg		150 kg	
Dimensions (W*D):	710x515 mm		700x1000 mm	700x1500 mm

5 AL-PS Alliance Movable table

Movable table is used for tools and components storage and transportation. Equipped with four 75 mm casters, 2 of which are with **brakes**.

- 3 shelves with heights adjustment
- Dimensions (W*H*D): 690 x 840 x 460 mm
- Load capacity: 150 kg.



When ordering, please mention whether ESD or technical version, and whether dark grey RAL 7012 or light grey RAL 7035 color required.



6 7 8 TT-02, TT-03, TT-04 transportation carts

Transportation carts are used for tools and components storage and transportation.

Metal carts are equipped with four 75 mm (for TT-02, TT-03 carts) or 125 mm (for TT-04 cart) casters, 2 of which are with brakes, and height adjustable shelves.

CODE	TT-02	TT-03	TT-04
Picture number	6	7	8
Dimensions (W*H*D):	470×990×840 mm	470×990×840 mm	615×1560×1270 mm
Quantity of shelves	2	3	4
Shelves height adjustment	140 – 800 mm	140 – 800 mm	190 – 1480 mm
Load capacity (kg)	100 kg	100 kg	100 kg

When ordering, please mention whether ESD or technical version, and whether dark grey RAL 7012 or light grey RAL 7035 color required.

MOVABLE TROLLEYS



1



2



3



4



1 ST-05 Movable trolley

2 ST-05 Comfort Movable trolley

Movable trolleys are used for tools and components storage and [transportation](#).

- 5 height-adjustable shelves and power panel with 5 grounded and 1 ungrounded sockets
- Lateral position of power panel
- 2 of 4 casters are with brakes
- Total load capacity: 150 kg

CODE	ST-05	ST-05 COMFORT
Dimensions (W×H×D):	500×1600×600 mm	460×1600×680 mm

3 ST-06 Movable trolley

Movable trolley is used for tools and components storage and [transportation](#).

- 5 height-adjustable shelves
- 2 of 4 casters are with brakes.
- Dimensions (W×H×D): 500×1605×600 mm
- Total load capacity: 150 kg

4 AL-ST Equipment trolley

Equipment trolley is designed for additional equipment storage and transportation. It has 5 height adjustable shelves and a power panel with 4 sockets and a switch. The panel is located on the side frame thus does not occupy any space on shelves. Equipment trolley side frames are manufactured of aluminum profile, which allows attaching small elements, and gives the whole unit elegant look. Trolley has 4 casters, 2 of which are with brakes as [supports](#).

- Dimensions (W×H×D): 690×1940×460 mm.
- Load capacity: 150 kg

When ordering, please mention whether ESD or technical version, and whether dark grey RAL 7012 or light grey RAL 7035 color required.



5

6

7

8

5 SKM Dual movable trolley

Dual Movable trolley for accessories is made of a rack coated with conductive powder paint, thus available only in ESD version. Lower shelf made of ESD laminated chipboard 25 mm thick. Trolley is equipped with four 75 mm casters (2 of them with brakes) and six rails for boxes. Attachable bins are ordered [separately](#).

- Load capacity: 100 kg
- Dimensions (W×H×D): 680×1600×460 mm

6 ST-R Movable repairing trolley

The trolley is equipped with 2 perforated panels in the upper part and a drawer unit with 5 telescoping drawers [lower](#).

- Dimensions:
 - Trolley dimensions (W×H×D): 600×1730×630 mm
 - Drawer unit dimensions (W×H×D): 500×800×590 mm
 - Perforated panels dimensions (W×H): 525×600 mm
- Perforated panel load capacity: 10 kg

7 ST-VR-01 Movable equipment trolley

Convenient equipment trolley with side handle allows tools and equipment storage on upper perforated panel and two lower shelves. All standard hooks (K-01 – K10) can be mounted to upper perforated panel. Movable trolley equipped with four casters, all with [brakes](#).

- Dimensions(W×H×D): 800×1600×690 mm
- Load capacity per shelf: 100 kg
- Trolley load capacity: 250 kg

8 SUS Movable packing trolley

Auxiliary trolley, designed for convenient polyethylene, damping film, paper and other packaging materials rolls clamping; maximum roll's width - 1.5 m. Movable packing trolley equipped with four 50 mm casters, all with [brakes](#).

- Dimensions (W×H×D): 1800×1240×600 mm
- Load capacity: 80 kg

When ordering, please mention whether ESD or technical version, and whether dark grey RAL 7012 or light grey RAL 7035 color required.

CABINETS AND WARDROBES



1a 2 3 4



1a



2



3



1b



1b

Cabinets and wardrobes

All cabinets have central lock.

Most models have 3 or 4 height adjustable shelves with 50 mm pitches.

For wardrobe and combined cabinets garment bar included.
 For SHDZH Sliding shutters cabinets inner dividers included.
 For SHKH cabinets 16 (SHKH-2) to 30 (SHKH-1) 360 mm telescoping drawers included.

- Drawers dimensions 310×100×370 mm.
- Load capacity per surface - 30 kg.

PICTURE NUMBER		DIMENSIONS (W×H×D), MM	WEIGHT, KG
SHD-1, SHD-2 Filing cabinets			
1a	SHD-1	1000×1950×550	80
	SHD-2	820×1850×450	62
1b	SHD-3	820×1000×450	40
SHO-1, SHO-2 Wardrobe cabinets			
2	SHO-1	1000×1950×550	68
	SHO-2	820×1850×450	52

When ordering, please mention whether ESD or technical version, and whether dark grey RAL 7012 or light grey RAL 7035 color required.



PICTURE NUMBER		DIMENSIONS (W×H×D), MM	WEIGHT, KG
	SHK-1, SHK-2 Combined cabinets		
3	SHK-1	1000×1950×550	78
	SHK-2	820×1850×450	58
	SHKH-1, SHKH-2 Drawers cabinets		
4	SHKH-1	820×1850×450	127
	SHKH-2	820×1060×450	69

Shelves dividers for SHKH cabinets

5 D-6/SH

Dividers for type SHKH drawers (360×100×310 mm). The set consists of 2 longitudinal and 4 transversal dividers. Up to 15 different sized cells can be [organized](#).

6 KD/SH mat

ESD mat that should be ordered separately if drawers dividers set is being ordered for technical version cabinets. KD/SH mat is necessary to provide drawers dividers set stability and [reliability](#).

When ordering, please mention whether ESD or technical version, and whether dark grey RAL 7012 or light grey RAL 7035 color required.

SLIDING SHUTTERS CABINETS



SHDZH-1 Sliding shutters cabinet

SHDZH-1 Sliding shutters cabinet is a compact metal cabinet with two sliding shutters and a lock in the middle. Each section equipped with 2 shelves and inner dividers to provide convenient documents [storage](#).

- Load capacity per shelf: 50 kg
- Dimensions (W×H×D): 615×1700×400 mm
- Available only in technical version

SHELVING



1



2



3

STU Shelving

Shelving is used for documents and components storage. Shelving (except for the STU-01) have height-adjustable supports and 5 height adjustable shelves with 50 mm pitches.

For STU-01 there are 6 height adjustable shelves with 50 mm pitches.

- Load capacity per shelf - 30 kg.
- Load capacity total:
 - 180 kg for STU-01,
 - 110 kg - for STU-02, STU- 03, STU-04, STU-05.

PICTURE NUMBER	DIMENSIONS (W×H×D), MM	
1	STU-01	820×1850×430
	STU-02	820×1850×430
2	STU-03	1000×1850×530
	STU-04	820×1950×430
	STU-05	1000×1950×530

STS Reinforced shelving

Height-adjustable supports. 4 height adjustable shelves with 50 mm pitches. No additional floor leveling required. Available only in technical version.

- Load capacity per shelf - 200 kg.
- Load capacity total - 640 kg.

PICTURE NUMBER	DIMENSIONS (W×H×D), MM	
3	STS-12	1200×1800×600
	STS-15	1500×1800×600

PL-1, PL-2, PL-ST5-12, PL-ST5-15 Additional shelves

Additional shelves for cabinets and shelving

SHELVES	TO BE USED FOR
PL-1	SHD-1, STU-03, STU-05
PL-2	SHD-2, SHD-3, STU-01, STU-02, STU-04
PO-ST5-12	STS-12
PO-ST5-15	STS-15

When ordering, please mention whether ESD or technical version, and whether dark grey RAL 7012 or light grey RAL 7035 color required.

MODULAR COUNTERS

Modular turntable counter

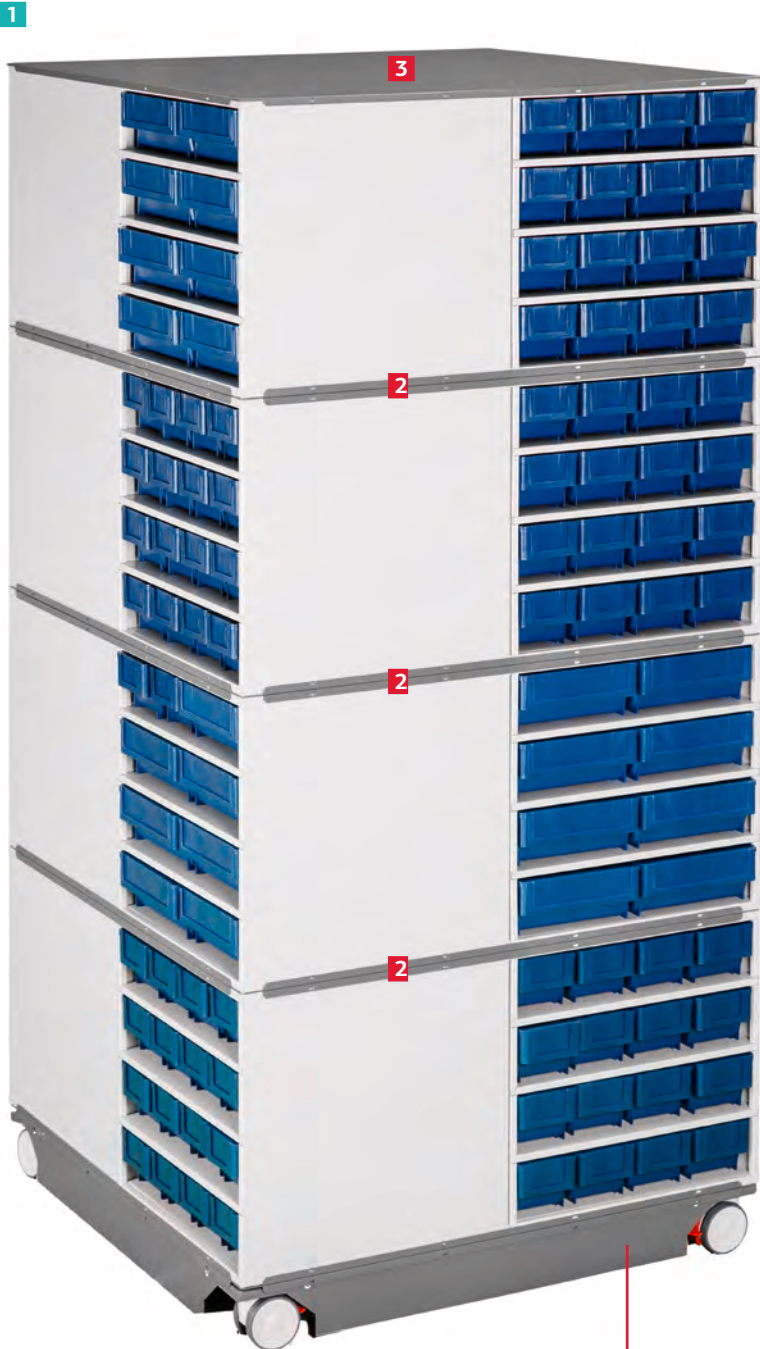

Turntable modular storage counter is a practical and high-capacity solution for components and tools keeping, that provides convenience of its usage in different production processes.

Turntable modular counter is equipped with bin cabinets containing 2 types of plastic bins: narrow and wide.

- **narrow** bin dimensions: 400×94×82 mm,
 - volume of 2.4 liter,
 - maximum load - up to 7.5 kg.
- **wide** bin dimensions: 400×188×82 mm,
 - volume of 4.3 liters,
 - maximum load - up to 10 kg.

Turntable modular storage counter can be ordered as a complete set or partially.

Modular storage counter in ESD version contains black antistatic plastic bins.

1 SP-01

Full modular counter set consists of 8 bin cabinets, each with 16 narrow bins and 8 bin cabinets, each with 8 wide bins and technical connecting/ turntable set. Full modular counter set is easily assembled of 16 bin cabinets placed in 4 levels, whereas each level contains 4 bin cabinets.

- Modular turntable counter dimensions: 800×1670×800 mm
- Maximum load capacity: 500 kg
- Weight: 200 kg.

SP-01/S-1

Bin cabinet with 16 narrow bins.

SP-01/S-2

Bin cabinet with 8 wide bins.

SP-01/K

Technical modules set that consists of

- 1 turntable base,
- 2 3 connecting pads,
- 3 top lid.

SP-01/S-1, **SP-01/S-2** and **SP-01/K** modules are necessary to built up a customized modular set. Standard **SP-01** set includes technical pads, base and top lid.



When ordering, please mention whether ESD or technical version required.

Modular stationary counter

Stationary modular storage counter is a practical and compact solution for components and tools keeping, that can be placed anywhere in production hall.

Stationary modular counter is equipped with bin cabinets containing 2 types of plastic bins: narrow and wide.

- **narrow** bin dimensions: 400×94×82 mm,
 - volume of 2.4 liter,
 - maximum load - up to 7.5 kg.
- **wide** bin dimensions: 400×188×82 mm,
 - volume of 4.3 liters,
 - maximum load - up to 10 kg.

Stationary modular storage counter is ordered in parts, bin cabinets and technical connecting pads [separately](#).

Modular storage counter in ESD version contains antistatic plastic bins.

Stationary modular storage counter is ordered in parts, bin cabinets and technical connecting pads separately.

Maximum of 4 bin cabinets can be placed in [a column](#).

1 SP-01/S-1

Bin cabinet with 16 narrow bins.

- Dimensions: 395×400×400 mm.

2 SP-01/S-2

Bin cabinet with 8 wide bins.

- Dimensions: 395×400×400 mm.

3 SP-01/PM

Connecting pad for bin cabinets.

Ordered if several bin cabinets need to be placed on one another to provide safer junction.



When ordering, please mention whether ESD or technical version required.

ESD CHAIRS

VKG C-100 ESD



ESD laboratory chair, covered with static dissipative fabric, can be equipped with five conductive glides or five ESD casters. Can be also equipped with ESD armrests, footrest and enlarged gaslift on [request](#).

- Back angle adjustment
- Seat height adjustment: 43 - 63 cm
- Resistance: less than 1 MOhm
- Weight: 7 kg
- Available colors: grey and blue

VKG C-200 ESD



ESD laboratory chair, covered with static dissipative fabric, can be equipped with five conductive glides or five ESD casters. Can be also equipped with ESD armrests, footrest and enlarged gaslift on [request](#).

- Back and seat angles adjustments
- Seat height adjustment: 43 - 63 cm
- Resistance: less than 1 MOhm
- Weight: 7,5 kg
- Available colors: grey and blue

VKG C-300 ESD



ESD laboratory chair with conductive incombustible polyurethane upholstery can be equipped with five conductive glides or five ESD casters. Can be also equipped with ESD armrests, footrest and enlarged gaslift on [request](#).

- Back angle adjustments
- Seat height adjustment: 43 - 57 cm
- Resistance: less than 1 MOhm
- Weight: 7,5 kg
- Cleanroom - suitable.

VKG C-400 ESD



ESD laboratory stool with conductive incombustible polyurethane upholstery can be equipped with five conductive glides or five ESD casters. Can be also equipped with ESD footrest and enlarged gaslift on [request](#).

- Seat height adjustment: 43 - 63 cm
- Resistance: less than 1 MOhm
- Weight: 4 kg
- Cleanroom - suitable.

Please, when ordering chair/stool, mention necessary gaslift type.

Gaslifts for VKG series



ESD chairs and armchairs originally equipped by KJ/200 gaslift, which allows to adjust seat height 43-63 cm from the floor. KJ/200 and KJ/260 gaslifts can be ordered [separately](#).

Seat height adjustment

- KJ/200 – 43...63 cm
- KJ/260 – 54...83 cm

Foot ring (support) for VKG series



Height-adjustable supportive foot ring. Recommended for chairs with extended [gaslifts](#).

Ring diameter

- JR-430 – 43 cm
- JR-600 – 60 cm

VKG F-05 ESD glides for all chairs



A set of 5 ESD glides may be ordered for all types of ESD chairs and ESD [stool](#).

P607A ESD casters for all chairs



A set of 5 ESD casters may be ordered for all types of ESD chairs and ESD [stool](#).

KT ESD armrests for VKG series



A set of ESD armrests can be additionally ordered for all types of ESD [chairs](#).

STREAM 280-SY



- 5 cm cold-foam seat and 3.5 cm cold-foam backrest
- seat height adjustment : 43 cm – 54 cm
- available in 2 colors (black and grey)
- extra strong aluminum 5-star base provides 120 kg load capacity
- available in both ESD and technical versions

STREAM 280-SY ESD Armchair is designed especially for workplaces where antistatic environment is required. It also provides individually adjustable ergonomic sitting. 5 years warranty guaranteed.

Can be equipped with ESD glides, ESD casters, armrests, higher gaslift with foot ring. For safety reasons a model equipped with higher gaslift and foot ring available only with glides.

GS CERTIFICATE fulfills standards:

- DIN EN 1335-1:2002-08 + B1:2002-11
- DIN EN 1335-2:2010-01
- DIN EN 1335-3:2009-08

- DIN EN 13761:2002-12

ERGONOMIC CERTIFICATE fulfills the standard:

- DIN EN ISO 9241-5:1999-088

TOX FREE CERTIFICATE pollutant free:

- Cadmium
- PAK
- Formaldehyd
- Azodyes

Accessories for STREAM 280-SY

BR-AL-CHR-ESD



Aluminum armrests with fixed shape and [height](#).

BR-207-1-CHR



Height-adjustable black nylon

armrests, polypropylene arm [pads](#).

- BR-AL-CHR-ESD - conductive type
- BR-207-1-CHR - insulating type

KJ/650-CHR



- set of higher gaslift with foot ring
- can be equipped with ESD glides only
- seat height 65 - 93 cm

ESD GARMENTS

ESD garments shield external objects from electrostatic discharge, which is generated on internal garments by friction.

VA Unisex Shortcut lab coat

VAE-M Men's lab coat, VAE-W Women's lab coat



- Machine washable at 60 °C
- At least 50 washing cycles without losing ESD characteristics
- Charge decay time: < 0.17 s
- Composition:
 - 66% polyester
 - 33% cotton
 - 1% conductive fibers

- Colors:
 - white
 - blue
 - grey

- Machine washable at 60 °C
- At least 50 washing cycles without losing ESD characteristics
- Charge decay time: < 0.17 s
- Composition:
 - 66% polyester
 - 33% cotton
 - 1% conductive fibers

VH-01 Antistatic bandana



Material:

- 66% polyester
- 33% cotton
- 1% conductive fibers

Colors:

- blue
- white
- grey

When ordering, mention necessary height (152-194 mm) and size (EUR 34-54).

VAK-M Men's costume, VAK-W Women's costume

VAT-W Women's trousers VAT-M men's trousers



- Machine washable at 60 °C
- At least 50 washing cycles without losing ESD characteristics
- Charge decay time: < 0.17 s
- Composition:
 - 66% polyester
 - 33% cotton
 - 1% conductive fibers
- Colors:
 - white, blue, grey
 - white and blue combined
 - white and grey combined

- Machine washable at 60 °C
- At least 50 washing cycles without losing ESD characteristics
- Charge decay time: < 0,17 s
- Composition:
 - 66% polyester
 - 33% cotton
 - 1% conductive fibers
- Colors:
 - white
 - blue
 - grey

VH-02 Antistatic cap

Material:

- 66% polyester
- 33% cotton
- 1% conductive fibers

Colors:

- blue
- white
- grey

Elastic band

Sizes:

- 54-62



CLEANROOM GARMENTS AND ACCESSORIES

Cleanroom Labcoats



Coats are intended for use in cleanrooms up to ISO Class 5 category.

- Surface resistance $10^6-10^9 \Omega$.
- Durability – up to 80 washes at 60°C.
- Material: Polyester.
- Colors: white and blue.
- Sizes: S, M, L, XL, XXL, XXX.

Cleanroom Jumpsuits



Jumpsuits are intended for use in cleanrooms up to ISO Class 5 category

- Surface resistance $10^6-10^9 \Omega$.
- Durability – up to 80 washes at 60°C.
- Material: Polyester.
- Colors: white and blue.
- Sizes: S, M, L, XL, XXL, XXXL.

CODE	SIZE	COLOR
51-400-0001	S	White
51-400-0002	M	White
51-400-0003	L	White
51-400-0004	XL	White
51-400-0005	XXL	White
51-400-0006	XXXL	White
51-400-0101	S	Blue
51-400-0102	M	Blue
51-400-0103	L	Blue
51-400-0104	XL	Blue
51-400-0105	XXL	Blue
51-400-0106	XXXL	Blue

CODE	SIZE	COLOR
51-400-0201	S	White
51-400-0202	M	White
51-400-0203	L	White
51-400-0204	XL	White
51-400-0205	XXL	White
51-400-0206	XXXL	White
51-400-0301	S	Blue
51-400-0302	M	Blue
51-400-0303	L	Blue
51-400-0304	XL	Blue
51-400-0305	XXL	Blue
51-400-0306	XXXL	Blue

Cleanroom Booties



Booties are intended for use in cleanrooms up to ISO Class 5 category.

- Resistance to ground $<3,5 \times 10^7 \Omega$
- Materials:
 - Top: Micro Fibre Synthetic PU;
 - Sole: Static Dissipative PU;
 - Fabric: Static Dissipative Polyester
- washable
- Color: white

CODE	SIZE
50-530-0035	35
50-530-0036	36
50-530-0037	37
50-530-0038	38
50-530-0039	39
50-530-0040	40
50-530-0041	41
50-530-0042	42
50-530-0043	43
50-530-0044	44
50-530-0045	45
50-530-0046	46
50-530-0047	47



Disposable Lab coats



Disposable lab coats are intended for use in cleanrooms up to ISO Class 6 category.

- Material: SMS (Spunbonded Meltblown Spunbonded), Density: 60 g/sqm, closed with plastic studs, 3 pockets
- Non-washable.
- Color: white
- Sizes: L, XL, XXL

CODE	SIZE
52-100-4203	L
52-100-4204	XL
52-100-4205	XXL

Cleanroom Gloves



Hypoallergenic gloves for cleanrooms, available in lengths of 23 cm and 30 cm, intended for use in cleanrooms up to ISO Class 5 category.

- Material: Nitrile
- Surface resistance: $< 10^{11} \Omega$
- Sizes: S, M, L

CODE	SIZE	LENGTH	PACKAGE QTY.
51-690-0701	S	23 cm	10
51-690-0702	M	23 cm	10
51-690-0703	L	23 cm	10
51-690-0704	S	30 cm	10
51-690-0705	M	30 cm	10
51-690-0706	L	30 cm	10

Disposable Hat



Disposable hats are intended for use in cleanrooms up to ISO Class 5 category.

- Material: SMS (Spunbonded Meltblown Spunbonded), Density: 20 g/sqm.
- Non-washable.
- Color: white

CODE	PACKAGE QTY
52-100-0001	100

Face Mask



Masks are intended for use in cleanrooms up to ISO Class 5 category.

- Material: Three-layer polypropylene
- Color: white

CODE	SIZE	PACKAGE QTY.
52-000-0060	N/A	100

Cleanroom Overshoes



Overshoes are intended for use in cleanrooms up to ISO Class 5 category.

- Material: SMS (Spunbonded Meltblown Spunbonded), Density: 50 g/sqm.
- Color: white

CODE	SIZE	PACKAGE QTY.
52-100-0014	N/A	100

ESD STORAGE AND PACKAGING

STANDARDIZED ESD TRAYS FOR BOARDS AND COMPONENTS STORAGE

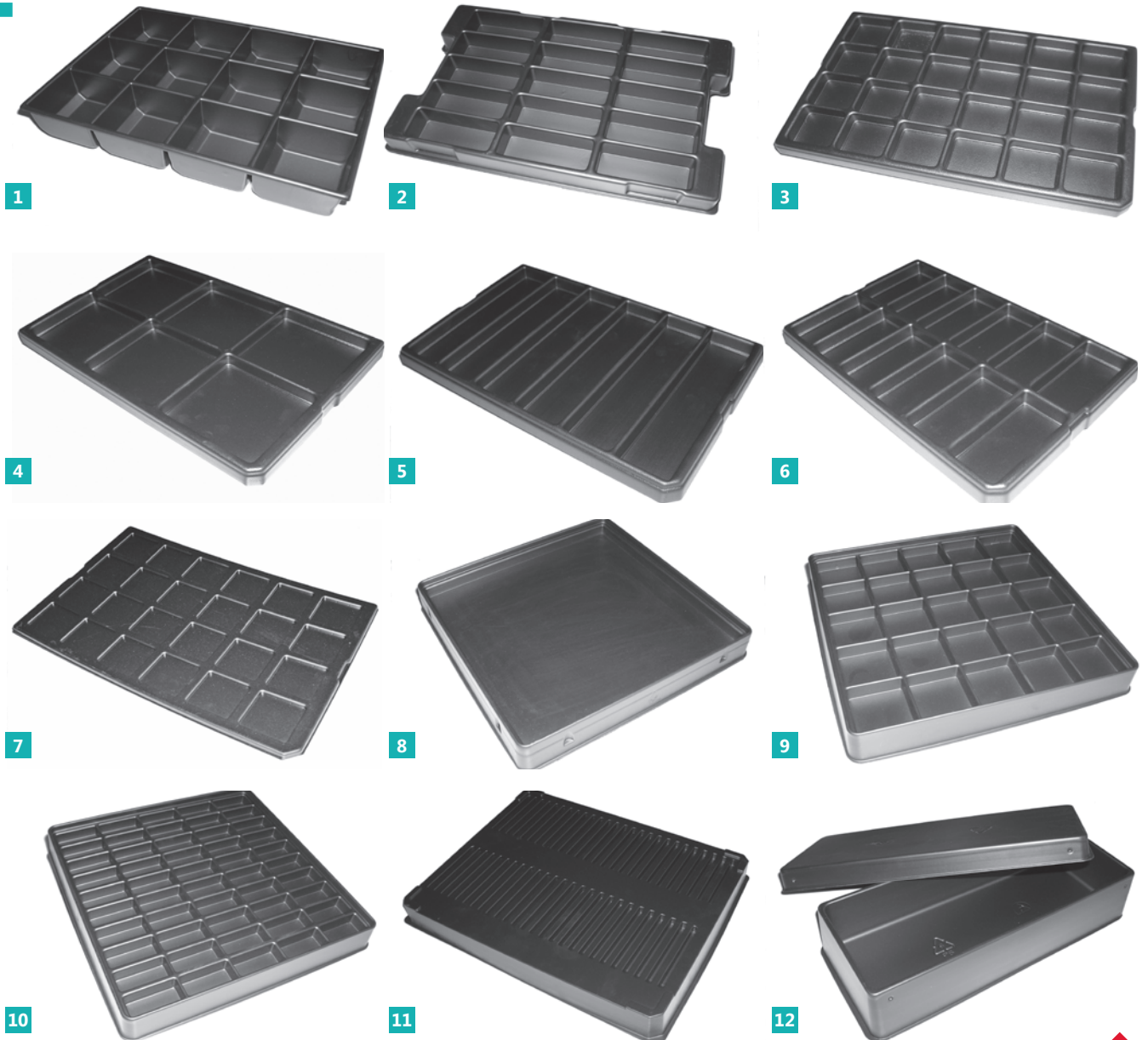

ESD trays are used for storage, transport and packaging of boards, components and finished units of electronic assembly. Made of polystyrene - dissipative material resistance $\leq 10^6 \Omega$. Color - black.

Nr	CODE	DIMENSIONS	THICKNESS	NUMBER OF CELLS
1	24-200-0650	330×250×50 mm	2,0 mm	12
2	24-200-1486	294×194×20 mm	2,0 mm	15
3	24-200-2273	350×225×20 mm	3,0 mm	24
4	24-200-2274	350×225×20 mm	3,0 mm	6
5	24-200-2531	350×225×20 mm	3,0 mm	6
6	24-200-2532	350×225×20 mm	3,0 mm	12
7	24-200-2533	350×225×5 mm	1,2 mm	24
8	24-200-2819	210×210×24 mm	1,2 mm	1
9	24-200-2820	210×210×24 mm	0,8 mm	25
10	24-200-2821	210×210×24 mm	0,8 mm	50
11	24-200-2833	440×348×43 mm	1,0 mm	52
12	24-200-4526	295×120×60 mm	1,5 mm	1

ANTISTATIC STORAGE

COCIS antistatic bins



Conductive ESD bins are used for small components and tools storage. Made of antistatic polypropylene. Can be easily attached to bin rails or fitted for free standing on a grounded surface. Bins of equal width can be stacked on one another.

- COCIS-A 96×105×45 mm
- COCIS-B 170×105×75 mm
- COCIS-C 250×148×130 mm
- COCIS-E 350×230×150 mm

Conductive Polypropylene Containers

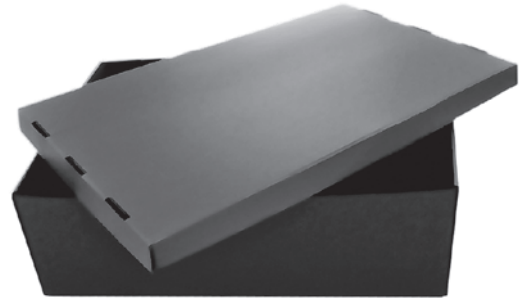

- Thickness - 2,5 mm
- Delivered unassembled
- Apertures for easy carrying on each side

CODE - BOX

CODE - BOX	CODE - LID	OUTER DIMENSIONS (MM)
23-175-7108	23-175-7110	400 × 300 × 180
23-175-7109	23-175-7110	400 × 300 × 228
23-175-7104	23-175-7106	600 × 400 × 180
23-175-7105	23-175-7106	600 × 400 × 228

CUSTOMIZED TRAYS FOR BOARDS AND COMPONENTS STORAGE

1 Customized packaging and shipping trays for PCB and components handling



Customized packaging and shipping trays are developed to specific customer needs and requirements to handle most PCB's and ESSD's. The complete process is controlled - the mold design and manufacturing and sheet extrusion production.

If we do not have a standard or common tray to suit your needs, if you require 100 off or 100 000 off. Speak to our technical sales team.

2 Customized foam inserts

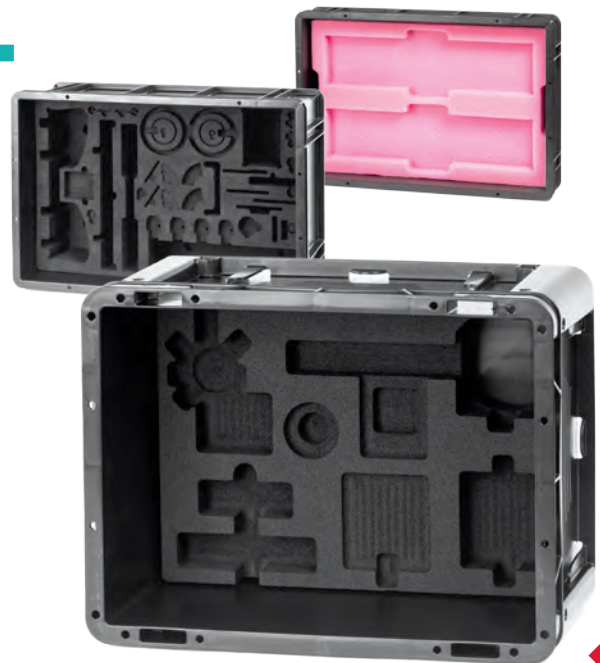

Customized foam inserts are made to order per customer specification, using conductive or dissipative antistatic foam - thickness 3-12 mm and a density 24-45 Kg/m³.

ESD MAGAZINES

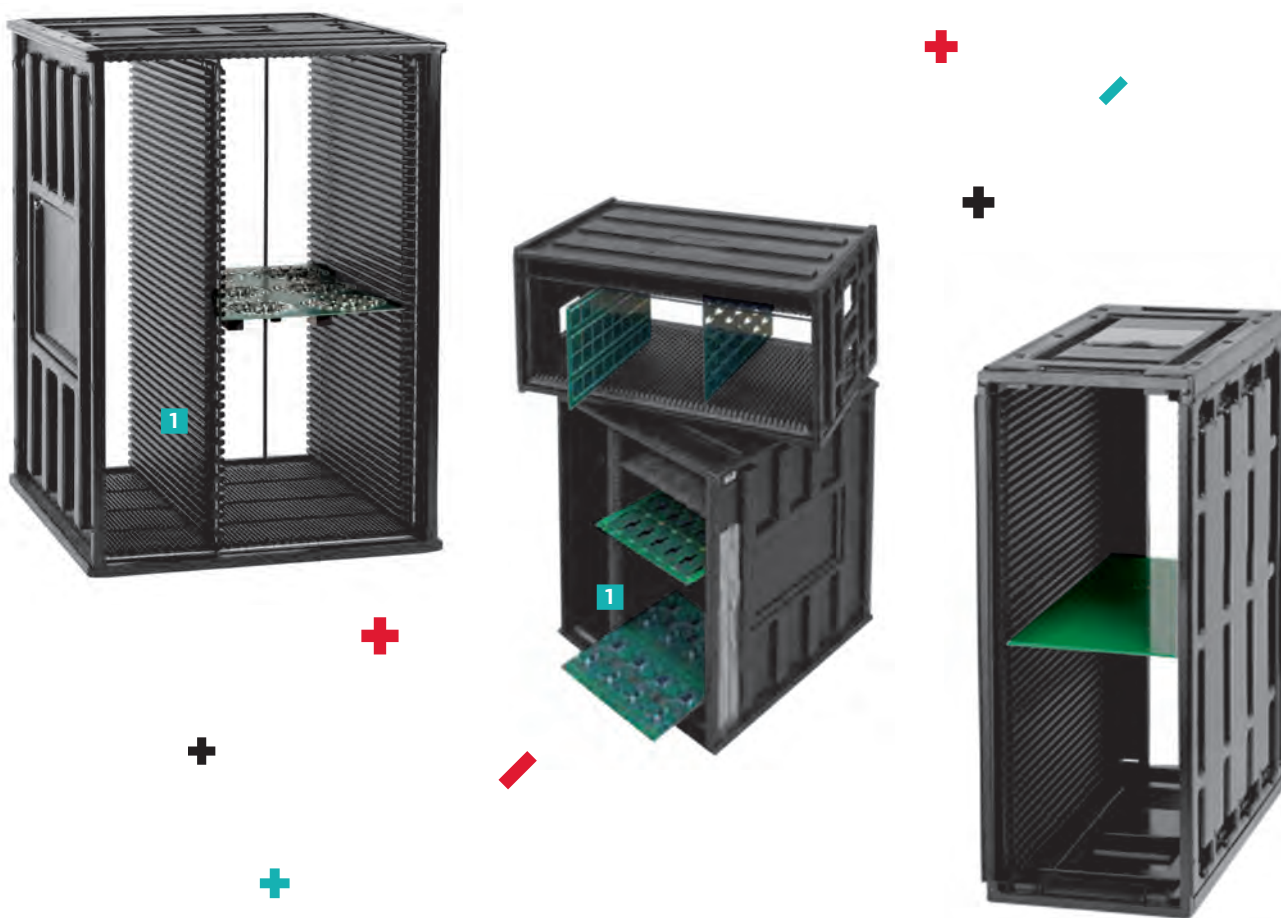

- Vertical pitch 10 mm
- Width adjustable by 5 mm pitch
- Strong construction from thermoformed plastic with metal reinforcement
- Light in weight and extremely rigid
- Assembled using rivets and ultrasonic welding
- Each groove is numbered
- Each magazine is delivered with a partition

2 versions available:

- PS for a 60°C heat resistance
- ABS/PC for 110°C heat resistance

PS magazines

Extra partitions and lids available on request.

CODE	DIMENSIONS	PCB	CODES FOR ADJUSTABLE PLATES
22-150-0943	320×350×560	247	97-001-0003
22-150-1154	370×370×560	297	97-001-0003
22-150-1187	400×425×560	327	97-001-0001
22-150-0817	420×460×560	357	97-001-0001
22-150-0891	450×425×560	377	97-001-0007
22-150-1083	470×480×560	397	97-001-0007

ABS/PC magazines

Extra partitions and lids available on request

CODE	DIMENSIONS	PCB	CODES FOR ADJUSTABLE PLATES
22-151-0943	320×350×560	247	97-011-0005
22-151-1154	370×370×560	297	97-011-0005
22-151-1187	400×425×560	327	97-011-0001
22-151-0817	420×460×560	357	97-011-0001
22-151-0891	450×425×560	377	97-011-0003
22-151-1083	470×480×560	397	97-011-0003

ESD QUICKFILL MAGAZINES



Quickfill Magazine

Quickfill magazines meet standard dimensions most frequently used on automated lines. Strong injection molded construction with metal reinforcement (top and bottom). Standardized plate that fits most popular brands on the [market](#).

- Not subject to accidental change in width; no wear of moving parts.
- Partition made of assembled plastic parts
- This system provides a better dimensional stability when strong temperature variations
- Meant for 50 PCB's

Material: Conductive PS (60°C heat resistance) or ABS/PC (110°C heat resistance) for plastic parts, galvanized Iron for metal [parts](#).

CODE	DIMENSIONS	MATERIAL VERSION	MIN./MAX. PCB SIZE
22-152-3060	460×400×563	PS	50/300
22-152-4060	355×320×563		50/250
22-152-6060	460×400×563		100/310
22-152-7060	535×460×570		50/390
22-152-8060	535×530×570		120/460
22-152-1120	460×400×563	ABS/PC	50/300
22-152-2120	355×320×563		50/250
22-152-3020	535×460×570		50/390

ESD PACKAGING

Black Conductive Tubing



- Complies with: 61340-5-1, 94/62/EC, 2002/95/EC
- Surface resistance: $<10^5 \Omega$
- Thickness: $100\mu (\pm 10\%)$

CODE	DIMENSIONS, M
20-851-0005	0.076 × 152
20-851-0010	0.102 × 152
20-851-0015	0.127 × 152

Non-standard dimensions [available](#)

Pink Dissipative Tubing



- Complies with: 61340-5-1, 94/62/EC, 2002/95/EC
- Surface resistance: $<10^{12} \Omega$
- Thickness: $90\mu (\pm 10\%)$
- Decay Time: from 1000V to 100V < 2 c
- Shelf life: 2 years

CODE	DIMENSIONS (m)
20-031-0005	0.1 × 250
20-031-0015	0.15 × 250
20-031-0020	0.2 × 250
20-031-0025	0.25 × 250
20-031-0030	0.3 × 250
20-031-0035	0.4 × 250
20-031-0040	0.5 × 250

Non-standard dimensions [available](#)

Dissipative Foam

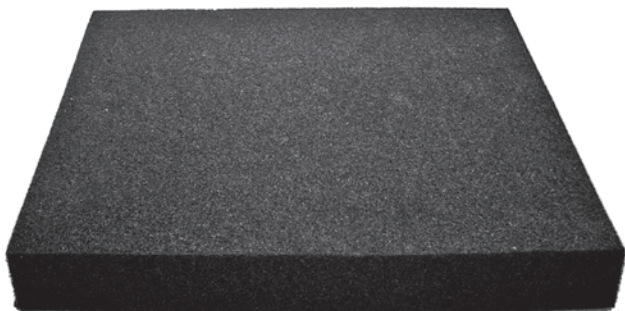

CODE	DIMENSIONS (mm)
26-403-0025	355×255×3
26-403-0008	555×355×3
26-412-0006	355×255×12
26-412-0005	555×355×12
26-406-0001	355×255×6
26-406-0002	555×355×6

Dissipative foam used in packaging to protect an object from mechanical damage. It also improves the shielding characteristics of the [packaging](#).

ESD CARDBOARD BOXES

Conductive coating and ESD marking. Non-standard dimensions available.

ESD boxes with pink PU foam



1 Static shielding and physical protection for small components

2 Static shielding and physical protection for PCBs

Supplied with pink PU flat foam on bottom and under lid.

CODE	DIMENSIONS (mm)
25-402-0105	40 × 40 × 15
25-402-0110	60 × 60 × 25
25-402-0115	100 × 100 × 38
25-402-0120	135 × 50 × 20
25-402-0205	178 × 127 × 38
25-402-0210	229 × 191 × 38
25-402-0215	229 × 191 × 64
25-402-0220	267 × 216 × 64
25-402-0225	318 × 267 × 64
25-402-0230	394 × 318 × 64
25-402-0235	521 × 394 × 38
25-402-0240	521 × 394 × 64

ESD boxes with black PU foam



Static field alternative and physical protection for shipping Microchips EPROMS/SIMMS.

Supplied with rigid foam on bottom.

CODE	DIMENSIONS (mm)
25-402-0005	90 × 30 × 15
25-402-0010	100 × 60 × 15
25-402-0015	120 × 100 × 15
25-402-0020	140 × 40 × 15
25-402-0025	160 × 80 × 15

ESD PINK BUBBLE BAGS

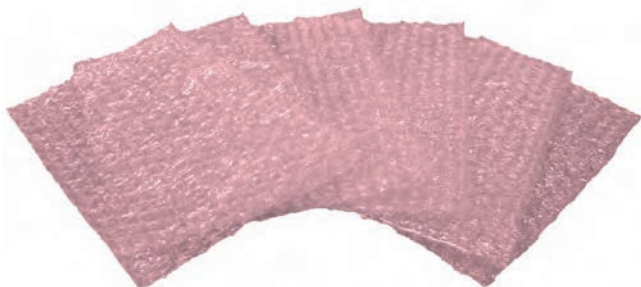

Excellent mechanical protection, 2 layers colamination.

- Material: Pink Polyethylene antistatic
- Thickness: 55μ (±10%)
- Surface resistance: < 10¹⁰ Ω
- Shelf life: 2 years - the bags must be stocked without any light and at a mini RH of 50%

CODE	DIMENSIONS (mm)
20-021-6000	100 × 150
20-021-6001	150 × 200
20-021-6002	175 × 250
20-021-6003	200 × 250
20-021-6004	250 × 300
20-021-6005	300 × 375
20-021-6020	400 × 700 + 100 lap

**TECHNICAL & ESD FURNITURE
ANTISTATIC EQUIPMENT**

VIKING VKG TOOLS



 **DIPPAUL**

PLZENSKA 155/113
150 00 PRAGUE 5
CZECH REPUBLIC
TEL: +420 2 5573 9633
E-MAIL: INFO@DIPPAUL.EU