

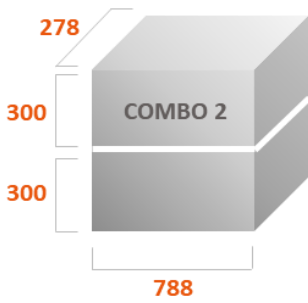

COMBO

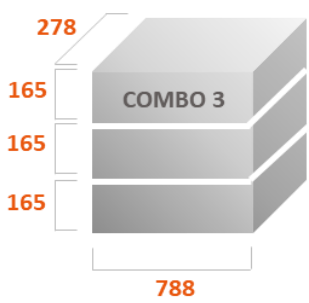

Usable space of baskets:
3x 788 x 278 x 300 mm



Usable space of baskets:
3x 788 x 278 x 165 mm



TWINGO



Usable space of frames:
2x 740 x 80 x 695 mm

*Note: Usable space between the nozzles is 80 mm
= 40 mm from axis to one and to second side.*

HyperSWASH III

Wash (Heat to 60 °C) + 1. Rinse (DI water) + 2. Rinse (DI water) + Dry

TECHNICAL PARAMETERS

Machine dimensions (WxLxH)	2010 x 2075 x 2615 mm (max)
Weight (without liquid, accessories)	1 000 kg
Machine noisiness	L _{Aeq} <70 dB
Power input	22 kVA
Maximum authorized load	20 kg per frame/basket (incl. frame/basket and clamping)

ADJUSTABLE PARAMETERS

Washing time	max. 495 min.
Cleaning medium temperature	20-60 °C
Rinsing time	max. 495 min.
Rinsing water temperature	20-40 °C
Conductivity	0-999 µS/cm (1. Rinse), 0-99 µS/cm (2. Rinse)
Drying time	max. 495 min.
Drying temperature	20-110 °C
Number of program registers (settings)	99
Working area: Left – Right (limit)	200-1000 mm

TECHNOLOGICAL PARAMETERS

Wash - TWINGO	2,5-1,9 bar
Pressure on the nozzles (max/ min)	
Wash - TWINGO	190 l/min
Flow (max)	
Rinse - TWINGO	1,8-1,3 bar
Pressure on the nozzles (max/ min)	
Rinse - TWINGO	180 l/min
Flow (max)	
Wash - COMBO 2	3,2-2,7 bar
Pressure on the nozzles (max/ min)	
Wash - COMBO 2	190 l/min
Flow (max)	
Rinse - COMBO 2	2,4-1,2 bar
Pressure on the nozzles (max/ min)	
Rinse - COMBO 2	135 l/min
Flow (max)	
Wash - COMBO 3	3,4-2,9 bar
Pressure on the nozzles (max/ min)	
Wash - COMBO 3	190 l/min
Flow (max)	
Rinse - COMBO 3	2,5-1,2 bar
Pressure on the nozzles (max/ min)	
Rinse - COMBO 3	140 l/min
Flow (max)	

Note: The approximate values of pressure and flow are mentioned. The real values can be slightly different depending on the tolerances of used components. These differences have no effect for cleaning process.

CONNECTION

Mains electricity	Voltage: 400/230 V AC 50 Hz
	Protection recommended: B 32 A
	Connection: 3/N/PE (socket 32 A)
Compressed air	Voltage: 208/120 V AC 60 Hz
	Protection recommended: B 63 A
	Connection: terminal block
Water inlet (voluntary)	Pressure: 0,6-0,8 MPa
	Class of air quality: 3.4.3. (according to ISO 8573-1)
	Connection: hose SMC ø 8 mm
Waste water outlet (from 1. rinse circuit) (voluntary)	Pressure: 3,5-5 bar (AD only)
	Flowrate: max. 30 l/min (AD only)
Air exhaust	Connection: hose 1"
	Capacity: min. 300-350 m ³ /h, under-pressure 1 000-1 500 Pa
	Connection: hose ø150 mm

REQUIRED SPACE

From the front min. 1 400 mm	Space for machine operation and maintenance (access to tanks with liquids)
From the right min. 700 mm	Access to door for maintenance
From the left min. 1 000 mm	Access area into switchboard (in accordance with IEC 60364-1:2005), main switch
From the rear min. 600 mm	Space for manipulation with filtration carts, machine maintenance (filter pads replacement, etc.)
From the above min. 700 mm	Space for door opening - ceiling height 2 700 mm

OPERATING / MAINTENANCE AREA

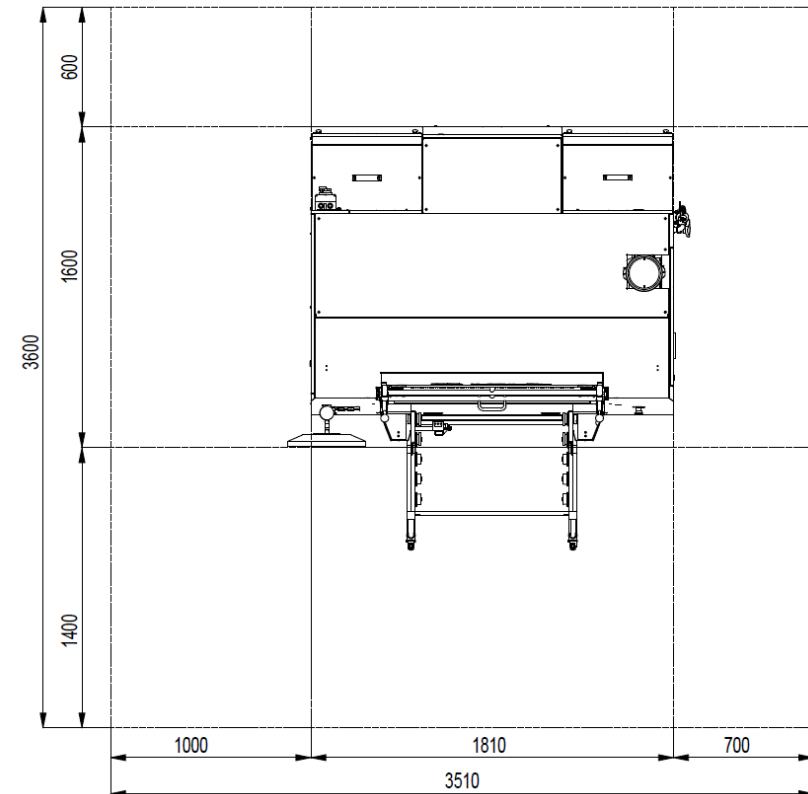

DIMENSIONS

HyperSWASH MANUAL

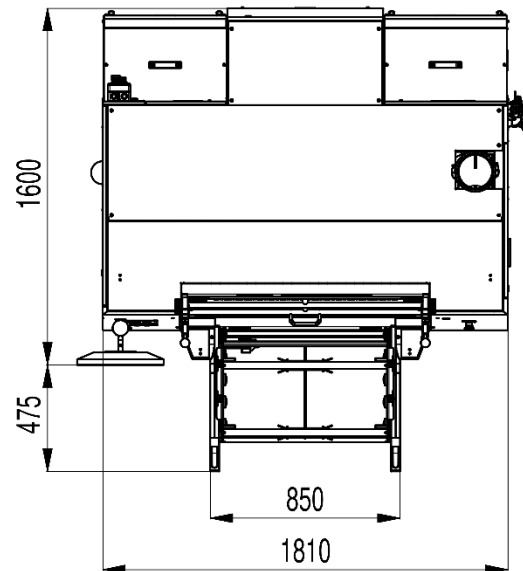
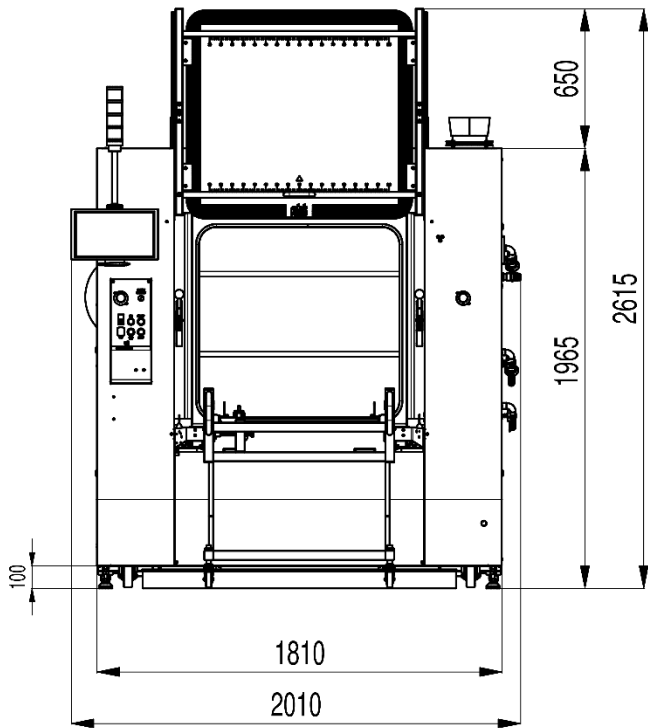

REQUIRED SPACE

HyperSWASH MANUAL

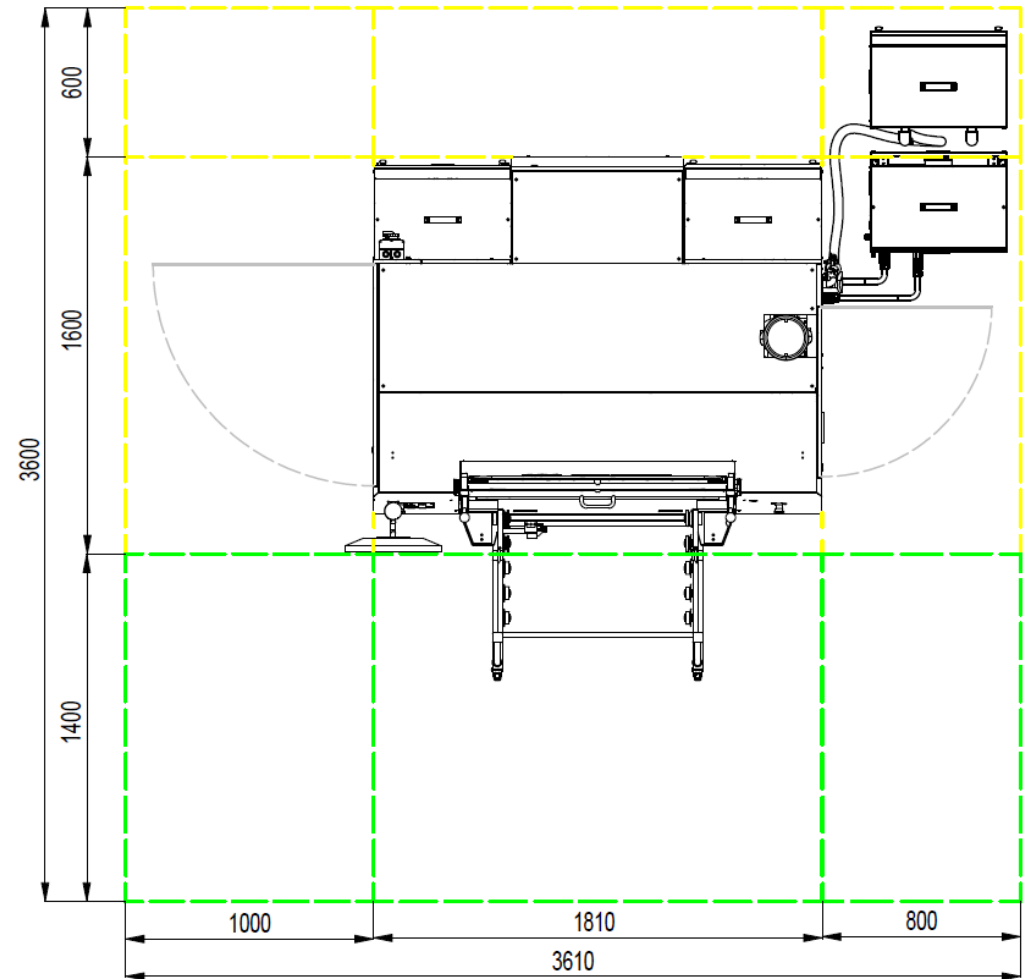

DIMENSIONS

HyperSWASH AUTO

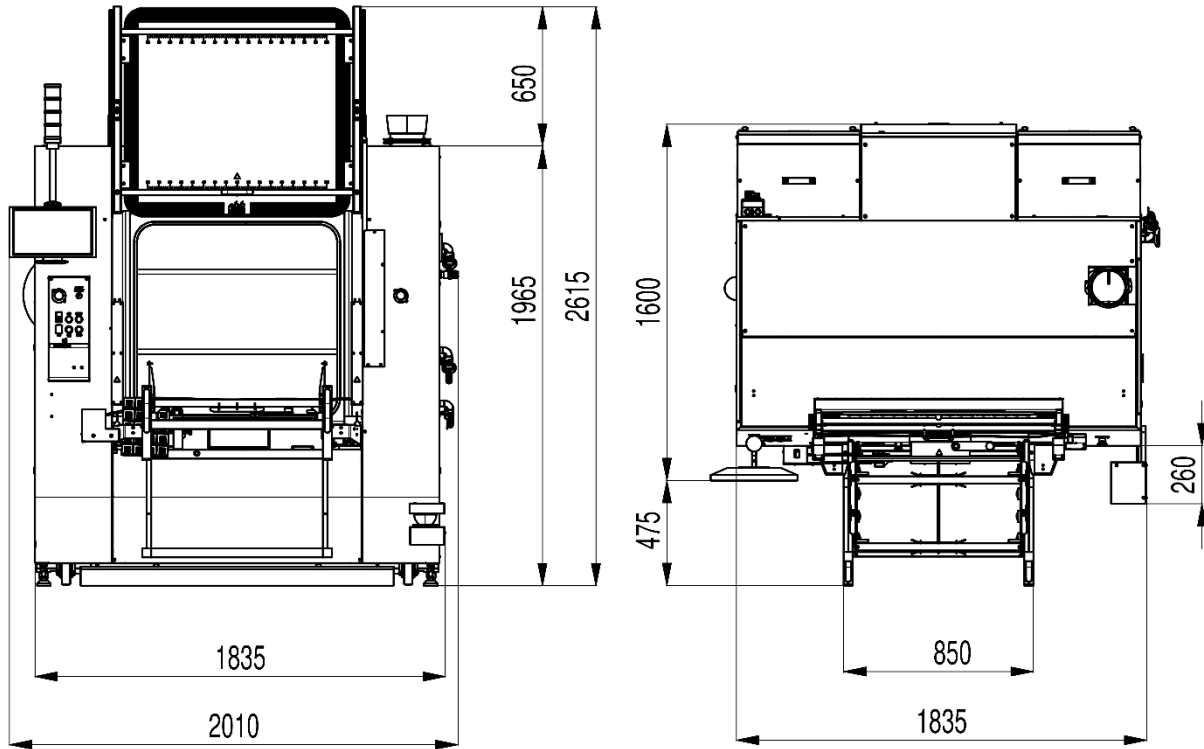

REQUIRED SPACE

HyperSWASH AUTO

Red marking is the actual space needed for Human Safety System scanner during automated loading only. No other objects are allowed in this space. It must stay clear.

